

Dell PowerEdge C6105
Systems
With 1U System Boards
**Hardware Owner's
Manual**

Regulatory Model B03S



Notes, Cautions, and Warnings



NOTE: A NOTE indicates important information that helps you make better user of your computer.



CAUTION: A CAUTION indicates potential damage to hardware or loss of data if instructions are not followed.



WARNING: A WARNING indicates a potential for property damage, personal injury, or death.

Information in this publication is subject to change without notice.

© 2013 Dell Inc. All rights reserved.

Reproduction of these materials in any manner whatsoever without the written permission of Dell Inc. is strictly forbidden.

Trademarks used in this text: Dell™, the DELL logo, and PowerEdge™ are trademarks of Dell Inc. AMD® is a registered trademark of Advanced Micro Devices, Inc.

Other trademarks and trade names may be used in this publication to refer to either the entities claiming the marks and names or their products. Dell Inc. disclaims any proprietary interest in trademarks and trade names other than its own.

Regulatory Model B03S

November 2013

Rev. A02

Contents

1	About Your System.....	11
	Accessing System Features During Startup	11
	Front-Panel Features and Indicators	12
	Hard-Drive Indicator Patterns	14
	Back Panel Features and Indicators	18
	NIC Indicator Codes	20
	Power and System Board Indicator Codes	21
	Power Supply Indicator Codes	22
	BMC Heart Beat LED	23
	Post Error Code	24
	Collecting System Event Log (SEL) for Investigation	24
	BMC	30
	Other Information You May Need	36
2	Using the System Setup Program	37
	Start Menu	37
	System Setup Options at Boot	38
	Console Redirection	38
	Setting up SOL (Serial Over LAN)	38
	Main Menu	41
	Main Screen	41
	BIOS Firmware	42
	System Firmware	42

Product Information.....	42
Processor.....	42
System Memory	43
Advanced Menu	43
CPU Configuration	44
Memory Configuration	48
SATA Configuration.....	50
Hyper Transport Configuration	52
PCI Configuration	53
USB Configuration	54
Boot Menu	55
Boot Settings Configuration	57
Boot Device Priority.....	58
Server Menu.....	59
LAN Configuration	61
Remote Access Configuration	62
View BMC System Event Log	63
Security Menu	64
Exit Menu.....	65
Command Line Interfaces for Setup options.....	66
3 Installing System Components	82
Safety Instructions	82
Recommended Tools	82
Inside the System	83
Hard Drives.....	84

Removing a Hard-Drive Blank	84
Installing a Hard-Drive Blank	85
Removing a Hard-Drive Carrier	85
Installing a Hard-Drive Carrier	86
Removing a Hard Drive From a Hard-Drive Carrier	87
Installing a Hard Drive into a Hard-Drive Carrier	88
Power Supplies	89
Recommended Configuration	90
Full Configuration	90
Removing a Power Supply	90
Installing a Power Supply	91
System-Board Assembly	92
Removing a System-Board Assembly	92
Installing a System-Board Assembly	93
Heat Sinks	94
Removing the Heat Sink	94
Installing the Heat Sink	95
Processors	96
Removing a Processor	96
Installing a Processor	97
Expansion-Card Assembly and Expansion Card	99
Removing the Expansion Card	99
Installing the Expansion Card	101
LSI 9260-8i Card	102
Removing the LSI 9260-8i Card	102

Installing the LSI 9260-8i Card	104
Cable Routing for LSI 9260-8i Card	106
LSI 9260-8i RAID Battery (Optional).....	107
Removing the LSI 9260-8i RAID Battery	107
Installing the LSI 9260-8i RAID Battery	108
Removing the LSI 9260-8i RAID Battery Carrier	109
Installing the LSI 9260-8i RAID Battery Carrier	110
LSI 9265-8i Card	110
Removing the LSI 9265-8i Card.....	110
Installing the LSI 9265-8i Card	113
Cable Routing for LSI 9265-8i Card	114
LSI 9265-8i RAID Battery (Optional).....	115
Removing the LSI 9265-8i RAID Battery Assembly.....	115
Installing the LSI 9265-8i RAID Battery Assembly	116
Removing the LSI 9265-8i RAID Battery	117
Installing the LSI 9265-8i RAID Battery	118
Expansion-Card Connector.....	119
Removing the Expansion-Card Connector.....	119
Installing the Expansion-Card Connector.....	120
Optional Daughter Cards.....	121
Removing the SAS Daughter Card.....	121
Installing the SAS Daughter Card	122
Cable Routing for SAS Daughter Card	123
Removing the NIC Daughter Card	124
Installing the NIC Daughter Card.....	126

Removing the Mellanox Card	127
Installing the Mellanox Card	130
System Memory	131
Supported DIMM Configuration	131
Removing the Memory Modules.....	133
Installing the Memory Modules	134
Interposer Extenders	136
Removing the Interposer Extender.....	136
Installing the Interposer Extender.....	137
System Battery.....	138
Replacing the System Battery.....	138
System Board.....	140
Removing a System Board.....	140
Installing a System Board.....	141
Opening and Closing the System	142
Opening the System.....	142
Closing the System	143
Cooling Fans.....	144
Removing a Cooling Fan.....	144
Installing a Cooling Fan.....	146
Power Distribution Boards	147
Removing a Power Distribution Board.....	147
Installing a Power Distribution Board.....	149
Cable Routing for Power Distribution Board.....	150
Fan Controller Board.....	151

Removing the Fan Controller Board	151
Installing the Fan Controller Board.....	152
Cable Routing for Fan Control Board.....	153
Middle Planes.....	154
Removing the Middle Planes.....	154
Installing the Middle Planes	159
Backplanes	161
Removing the Backplane	161
Installing the Backplane	164
Expander Card (Optional).....	165
Removing the Expander Card.....	165
Installing the Expander Card	169
Front Panels	170
Removing the Front Panel.....	170
Installing the Front Panel.....	173
Sensor Boards	174
Removing the Sensor Board for 3.5" HDD System.....	174
Installing the Sensor Board for 3.5" HDD System	176
Removing the Sensor Board for 2.5" HDD System.....	177
Installing the Sensor Board for 2.5" HDD System	180
4 Troubleshooting Your System.....	182
Safety First – For You and Your System.....	182
Installation Problems	182
Troubleshooting System Startup Failure	183
Troubleshooting External Connections	183

	Troubleshooting the Video Subsystem	183
	Troubleshooting a USB Device	183
	Troubleshooting a Serial I/O Device	184
	Troubleshooting a NIC.....	185
	Troubleshooting a Wet System	186
	Troubleshooting a Damaged System	187
	Troubleshooting the System Battery	187
	Troubleshooting Power Supplies	188
	Troubleshooting System Cooling Problems	189
	Troubleshooting a Fan	189
	Troubleshooting System Memory.....	190
	Troubleshooting a Hard Drive	192
	Troubleshooting a Storage Controller	193
	Troubleshooting Expansion Cards.....	195
	Troubleshooting Processors	196
	IRQ Assignment Conflicts	197
5	Jumpers and Connectors.....	198
	System Board Connectors.....	198
	Backplane Connectors	200
	3.5" Hard-Drive Backplane.....	200
	2.5" Hard-Drive Backplane.....	202
	2.5" Hard-Drive Backplane Expander Card Connectors	204
	Middle Plane Connectors	205
	Interposer Extender Connectors	206
	SAS Daughter Card Connectors.....	207

	NIC Daughter Card Connectors	208
	Fan Controller Board Connectors	209
	Power Distribution Board Connectors	210
	Sensor Board Connectors	211
	Jumper Settings	212
	System Configuration Jumper Settings	212
	Backplane Jumper Settings	213
	Backplane Expander Card Jumper Settings	214
6	Getting Help	215
	Contacting Dell	215
7	Index	216

About Your System

Accessing System Features During Startup

The following keystrokes provide access to system features during startup.

Keystroke	Description
<F2>	Enters the System Setup program. See “Start Menu” on page 37.
<F11>	Enters the BIOS Boot Manager. See “System Setup Options at Boot” on page 38.
<F12>	Starts Preboot eXecution Environment (PXE) boot.
<Ctrl><C>	Enters the SAS 2008 Daughter Card Configuration Utility. For more information, see the SAS adapter documentation.
<Ctrl><H>	Enters the LSI 9260 configuration utility. For more information, see the documentation for your SAS RAID card.
<Ctrl><H>	Enters the LSI 9265 configuration utility. For more information, see the documentation for your SAS RAID card.
<Ctrl><S>	Enters the utility to configure NIC settings for PXE boot. For more information, see the documentation for your integrated NIC.
<Ctrl><HOME>	BIOS recovery during Boot Block.

Front-Panel Features and Indicators

Figure 1-1. Front Panel—3.5" x12 Hard Drives With Four Motherboards

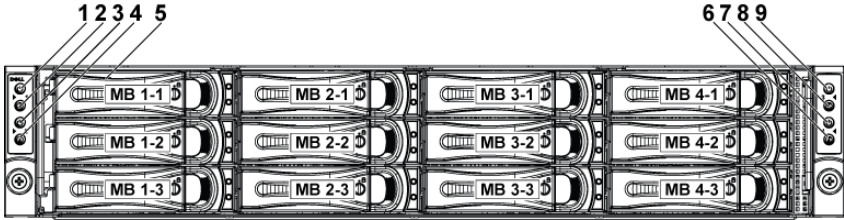

Figure 1-2. Front Panel—3.5" x12 Hard Drives With Two Motherboards

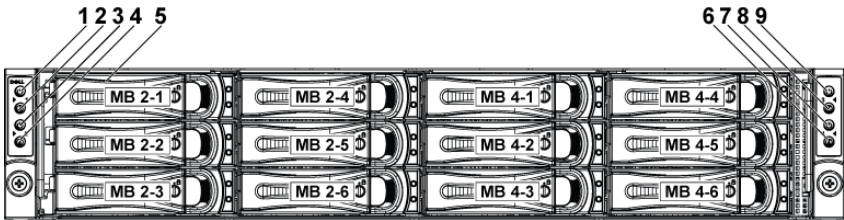

Figure 1-3. Front Panel—2.5" x24 Hard Drives With Four Motherboards

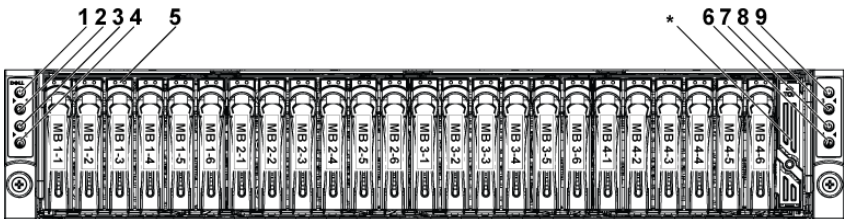
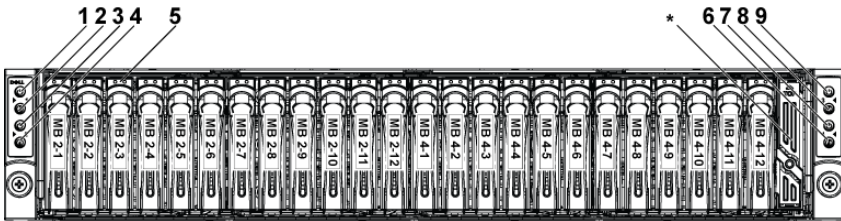



Figure 1-4. Front Panel 2.5" Hard Drives With Two Motherboards



Item	Indicator, Button Or Connector	Icon	Description
1	Power-on indicator/ system state indicator/ power button for motherboard 1		The power-on indicator turns to green when the system power is on. The power-on indicator turns to amber when the system critical event occurs.
3	Power-on indicator/ system state indicator/ power button for motherboard 2		The power button controls the DC power supply output to the system. NOTE: When powering on the system, the video monitor can take from several seconds to over 2 minutes to display an image, depending on the amount of memory installed in the system.
7	Power-on indicator/ system state indicator/ power button for motherboard 4		NOTE: On ACPI-compliant operating systems, turning off the system using the power button causes the system to perform a graceful shutdown before power to the system is turned off.
9	Power-on indicator/ system state indicator/ power button for motherboard 3		NOTE: To force an ungraceful shutdown, press and hold the power button for 5 seconds.

Item	Indicator, Button Or Connector	Icon	Description
2	System identification indicator/button for motherboard 1		The identification button can be used to locate a particular system and system board within a chassis. When the button is pushed, the blue system status indicator on the front and back blink until the button is pushed again.
4	System identification indicator/button for motherboard 2		
6	System identification indicator/button for motherboard 4		
8	System identification indicator/button for motherboard 3		
5	Hard Drives		Up to twelve hot-swappable 3.5-inch hard drives. Up to twenty four hot-swappable 2.5-inch hard drives.
*	Drive Cover		Applicable only for 2.5-inch hard drive system.

Hard-Drive Indicator Patterns

Figure 1-5. Hard Drive Indicators

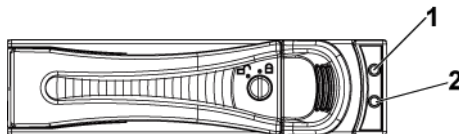

1 hard-drive activity indicator (green)

2 hard-drive status indicator (green and amber)

Table 1-1. Hard Drive Status Indicators—For 2.5"/3.5" Hard-Drive Backplane With CPLD

Controller	HDD Type	Function	Activity LED	Status LED	
			Green	Green	Amber
SP5100	SATA2	Drive on-line	Off/ Blinking when active	On	Off
		Fail	Off	On	Off
LSI 9260 /LSI 9265 /LSI 2008	SAS	Slot Empty	Off	Off	Off
	/SATA2	Drive On-line/Access	Blinking when active	On	Off
		Drive Fail	Off/ Blinking when active	Off	Blinking 2Hz
		Drive Rebuild	Blinking when active	Blinking 1Hz	Off
		Drive Identify	Blinking when active	Blinking 2Hz	Off

Table 1-2. Hard Drive Status Indicators – For 2.5” Hard-Drive Backplane With Expander





Controller	HDD Type	Function	Activity LED	Status LED	
			Green	Green	Amber
LSI 9260 / LSI 9265	SAS /SATA2	Slot Empty	Off	Off	Off
		Drive On-Line	Off/ Blinking when active	On	Off
		Drive Identify/ Preparing for removal	Off/ Blinking when active	On 250 ms Blinking 2Hz Off 250 ms	Off
		Drive Rebuild	Off/ Blinking when active	On 400 ms Blinking 2Hz Off 100 ms	Off
		Drive Fail	Off/ Blinking when active	Off	On 125 ms Blinking 4Hz Off 125 ms
		Predicted Failure (SMART)	Off/ Blinking when active	On 500 ms Off 500 ms Blinking 0.5Hz Off 1000 ms	On 500 ms Off 500 ms Blinking 0.5Hz Off 1000 ms
		Rebuild Abort	Off	On 3000 ms Off 3000 ms Blinking 0.08Hz Off 3000 ms Off 3000 ms	On 3000 ms Off 3000 ms Blinking 0.08Hz Off 3000 ms Off 3000 ms

Controller	HDD Type	Function	Activity LED	Status LED	
			Green	Green	Amber
LSI 2008	SAS /SATA2	Slot Empty	Off	Off	Off
		Drive On-Line	Off/ Blinking when active	On	Off
		Drive Identify/ Preparing for removal	Off/ Blinking when active	On 250 ms Blinking 2Hz Off 250 ms	Off
		Drive Rebuild	Off/ Blinking when active	On 400 ms Blinking 2Hz Off 100 ms	Off
		Drive Fail	Off/ Blinking when active	Off	On 125 ms Blinking 4Hz Off 125 ms

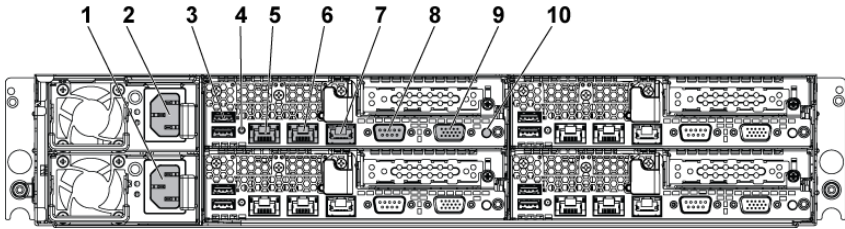
Back Panel Features and Indicators

Figure 1-6. Back Panel—Four System Boards



Item	Indicator, Button Or Connector	Icon	Description
1	Power supply 2		470 W/750 W/1100 W/1400 W
2	Power supply 1		470 W/750 W/1100 W/1400 W
3	USB ports (2)		Connect USB devices to the system. The ports are USB 2.0-compliant.
4	System identification indicator		Both the systems management software and the identification buttons located on the front can cause the indicator to flash blue to identify a particular system and system board. Lights amber when the system needs attention due to a problem.
5	NIC connector 1		Embedded 10/100/1000 NIC connectors.
6	NIC connector 2		Embedded 10/100/1000 NIC connectors.
7	Management port		Dedicated management port.



Item	Indicator, Button Or Connector	Icon	Description
8	Serial port		Connects a serial device to the system.
9	VGA port		Connects a VGA display to the system.
10	Power button		<p>The power button controls the DC power supply output to the system.</p> <p>NOTE: When powering on the system, the video monitor can take from several seconds to over 2 minutes to display an image, depending on the amount of memory installed in the system.</p> <p>NOTE: On ACPI-compliant operating systems, turning off the system using the power button causes the system to perform a graceful shutdown before power to the system is turned off.</p> <p>NOTE: To force an ungraceful shutdown, press and hold the power button for five seconds.</p>

Figure 1-7. Enumeration Four System Boards

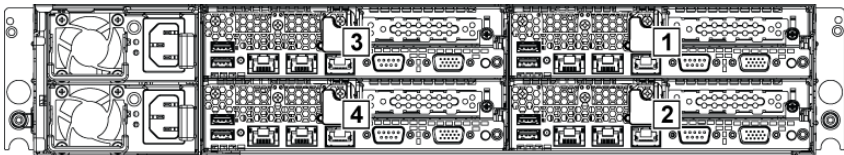
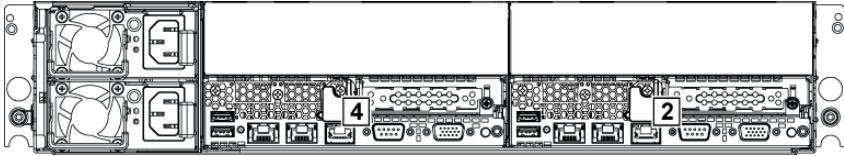
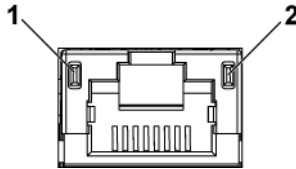

Figure 1-8. Enumeration Two System Boards



NIC Indicator Codes

Figure 1-9. NIC Indicators



1 speed indicator

2 link/activity indicator

NIC Status Indicator (Speed)	Condition
Solid green	Linking at 100 Mbps speed
Blinking green	Port identification with 10 or 100 Mbps speed
Solid amber	Linking at 1 Gbps speed
Blinking amber	Port identification with 1 Gbps speed
Off	Linking at 10Mbps speed when the link/activity LED is green; no link when the link/activity LED is off.

NIC Status Indicator (Link/Activity)	Condition
Solid green	LAN linking/No access
Blinks green	LAN accessing
Off	No link

Figure 1-10. NIC Indicators (BMC Management Port)

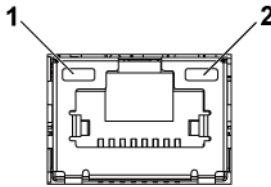

1 speed indicator

2 link/activity indicator

NIC Status Indicator (Speed)	Condition
Solid green	Linking at 100 Mbps speed
Solid amber	Linking at 1 Gbps speed
Off	Linking at 10 Mbps speed when the link/activity LED is solid green; no link when the link/activity LED is off.

NIC Status Indicator (Link/Activity)	Condition
Solid green	LAN linking/Accessing
Off	No link

Power and System Board Indicator Codes

The LEDs on the system front panel and back panel display status codes during system startup. For location of the LEDs on the front panel, see Figure 1-1 for 3.5” hard drive and Figure 1-3 for 2.5” hard drive systems. For location of the LEDs on the back panel, see Figure 1-6. Table 1-3 lists the status associated with the status codes.

Table 1-3. Status Indicator Codes

Component	Indicator	Condition
Power-on indicator	Steady Green	Power On S0/S1
	Blinks Amber	BMC Critical condition event in Power Off mode S5
	Blinks Green/Amber	BMC Critical condition event in Power On mode S0/S1
System identification indicator	Steady Blue	IPMI Via OEM Command On
	Blinks Blue	IPMI using Chassis Identify Command Blink On or ID Button Press ID On
	Off	IPMI using Chassis Identify Command Off or ID Button Press ID Off

Power Supply Indicator Codes

Figure 1-11. Power Supply Status Indicator

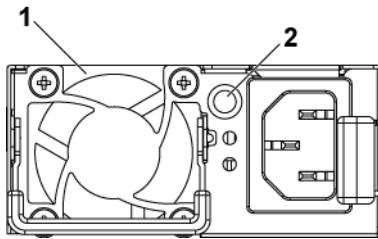

1 power supply

2 AC power LED

AC Power LED	Condition
Solid green	Power supply is on (AC OK/DC OK) or in standby mode (90 VAC-264 VAC for 470W/750W/1100W, 180 VAC-264 VAC for 1400W)
Solid yellow	Power supply is at fault condition (UVP/OVP/OCP/SCP/OTP/Fan Fault)
Off	Power supply is off or AC input voltage is out of normal operating range (90 VAC-264 VAC for 470W/750W/1100W, 180 VAC-264 VAC for 1400W)

BMC Heart Beat LED

The system board provides BMC heart beat LED (D5) for BMC debugs. When the system AC power is on, the BMC heart beat LED lights green. When the BMC firmware is ready, the BMC heart beat LED blinks.

Figure 1-12. BMC Heart Beat LED

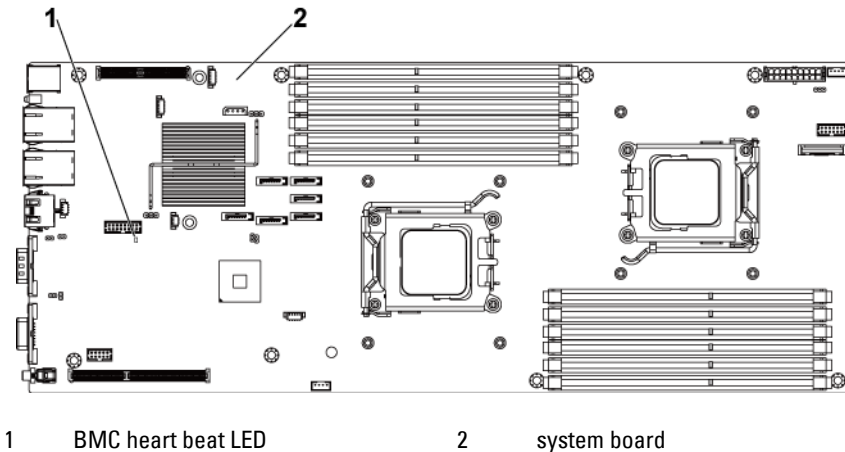

Post Error Code

Collecting System Event Log (SEL) for Investigation

Whenever possible, the BIOS displays the current boot progress codes on the video screen. Progress codes are 32-bit quantities plus optional data. The 32-bit numbers include class, subclass, and operation information. The class and subclass fields point to the type of hardware that is being initialized. The operation field represents the specific initialization activity. Based on the data bit availability to display progress codes, a progress code can be customized to fit the data width. The higher the data bit, the higher the granularity of information that can be sent on the progress port. The progress codes may be reported by the system BIOS or option ROMs. The Response section in the following table is divided into 3 types:

- 1 **Warning or Not an error** – The message is displayed on the screen. An error record is logged to the SEL. The system will continue booting with a degraded state. The user may want to replace the erroneous unit.
- 2 **Pause** – The message is displayed on the screen, an error is logged to the SEL, and user input is required to continue. The user can take immediate corrective action or choose to continue booting.
- 3 **Halt** – The message is displayed on the screen, an error is logged to the SEL, and the system cannot boot unless the error is resolved. The user needs to replace the faulty part and restart the system.

Error Code	Error Message	Response	Error Cause	Recovery Method
0000	Timer Error	Pause	Timer8254 failed	Board repair
0003	CMOS Battery Low	Pause	CMOS battery low	Change battery
0004	CMOS Settings Wrong	Pause	Diagnostic status byte shown an error	Load CMOS default setting
0005	CMOS Checksum Bad	Pause	CMOS checksum incorrect or BIOS update	Load CMOS default setting

Error Code	Error Message	Response	Error Cause	Recovery Method
000B	CMOS Memory Size Wrong	Pause	Base memory size error	Change DIMM or board repair
000C	RAM Read/Write Test Failed	Pause	No usable system memory	Change DIMM
000E	Floppy A: Driver Error	Pause	Floppy controller error	Board repair
000F	Floppy B: Driver Error	Pause	Floppy controller error	Board repair
0012	CMOS Date/Time Not Set	Pause	Indicate invalid Date/Time in CMOS diagnostic status byte	Reset Date/Time
0040	Refresh Timer Test Failed	Halt	Unrecoverable system-board failure	Board repair
0041	Display Memory Test Failed	Pause	Unrecoverable system-board failure	Board repair
0042	CMOS Display Type Wrong	Pause	Unrecoverable system-board failure	Board repair
0044	DMA Controller Error	Halt	Unrecoverable system-board failure	Board repair
0045	DMA-1 Error	Halt	Unrecoverable system-board failure	Board repair
0046	DMA-2 Error	Halt	Unrecoverable system-board failure	Board repair
0047	Unknown BIOS error. Error code = 0047	Halt	Unspecified	Board repair

Error Code	Error Message	Response	Error Cause	Recovery Method
0048	Password Check Failed	Halt	Preboot user password violation	Clear password by switch
0049	Unknown BIOS error. Error code = 0049	Halt	Unspecified	Board repair
004A	Unknown BIOS error. Error code = 004A	Pause	Unspecified	Board repair
004B	Unknown BIOS error. Error code = 004B	Pause	Unspecified	Board repair
005D	S.M.A.R.T. Command Failed S.M.A.R.T. Status BAD, Backup and Replace	Pause	HDD/ATAPI/IDE device failure	Change HDD
005E	Password Check Failed	Pause	Preboot user password violation	Clear Password by switch
0060	Primary Master Hard Disk Error	Pause	HDD/ATAPI/IDE device failure	Change HDD
0061	Primary Slave Hard Disk Error	Pause	HDD/ATAPI/IDE device failure	Change HDD
0062	Secondary Master Hard Disk Error	Pause	HDD/ATAPI/IDE device failure	Change HDD
0063	Secondary Slave Hard Disk Error	Pause	HDD/ATAPI/IDE device failure	Change HDD
0080	Primary Master Drive – ATAPI Incompatible	Pause	HDD/ATAPI/IDE device failure	Change HDD
0081	Primary Slave Drive – ATAPI Incompatible	Pause	HDD/ATAPI/IDE device failure	Change HDD
0082	Secondary Master Drive – ATAPI Incompatible	Pause	HDD/ATAPI/IDE device failure	Change HDD
0083	Secondary Slave Drive – ATAPI Incompatible	Pause	HDD/ATAPI/IDE device failure	Change HDD

Error Code	Error Message	Response	Error Cause	Recovery Method
0160	The processors installed in your system are not able to match their frequencies.	Pause	CPU mix installed is not supported.	Install same model CPU
0162	The processors installed in your system do not have the same cache size.	Halt	CPU mix installed is not supported.	Install same model CPU
0163	The processor(s) installed in your system are not known by the BIOS. Please contact your BIOS vendor for appropriate updates.	Pause	Unknown CPU	Install correct CPU
0164	Multiple core processors cannot be installed with single core processors.	Halt	CPU mix installed is not supported.	Install same model CPU
0165	The processor(s) installed in your system are of an unknown revision. Please contact your BIOS vendor for appropriate updates.	Pause	Unknown CPU	Install correct CPU
4100	Node(s) - no valid DIMM configuration detected	Pause	DIMM bad	Change DIMM
4101	DIMM(s) checksum error detected	Pause	DIMM bad	Change DIMM
4102	DIMM module type(buffer) mismatch	Pause	DIMM bad	Change DIMM
4103	DIMM CL/T mismatch	Pause	DIMM bad	Change DIMM
4104	DIMM organization mismatch (128-bit)	Pause	DIMM bad	Change DIMM
4105	SPD missing Trc or Trfc info	Pause	DIMM bad	Change DIMM

Error Code	Error Message	Response	Error Cause	Recovery Method
4106	SPD missing byte 23 or 25	Pause	DIMM bad	Change DIMM
4107	Bank interleave requested but not enabled	Warning	DIMM bad	Change DIMM
4108	Dram ECC requested but not enabled	Pause	DIMM bad	Change DIMM
4109	Online spare requested but not enabled	Pause	DIMM bad	Change DIMM
410A	DIMM(s) Running in Minimum Mode	Pause	DIMM bad	Change DIMM
410B	No DQS Receiver Enable pass window found	Pause	DIMM bad	Change DIMM
410C	DQS Rcvr En pass window CHA to CHB too large	Pause	DIMM bad	Change DIMM
410D	DQS Rcvr En pass window too small (far right of dynamic range)	Pause	DIMM bad	Change DIMM
4160	The processor(s) installed in your system are not multiprocessing capable.	halt	Unknown CPU	Install correct CPU
5120	CMOS cleared by jumper	Pause	CMOS clear by jumper	No action
5121	Password cleared by jumper	Pause	Password clear by jumper	No action
8101	Warning! USB Host Controller not found at the specified address!!!	Warning	USB Host controller bad.	No action
8102	Error! USB device failed to initialize!!!	Warning	USB init fail.	Check the USB device connected.
8103	Warning! Unsupported UBS device found and	Warning	Detected an unsupported USB	Check the USB device

Error Code	Error Message	Response	Error Cause	Recovery Method
	disabled!!!		device	connected.
8104	Warning! Port 60h/64h emulation is not supported by this USB Host Controller!!!	Warning	Host controller not supported 60h/64h emulation.	Board repair
8105	Warning! EHCI controller disabled. It requires 64bit data support in the BIOS.	Pause	Check whether this host controller needs 64bit data structure or not.	Board repair
8400	Warning!! Insufficient memory! Remote access is disabled.	Warning	Not enough memory for serial redirection.	Board repair
8601	Error: BMC Not Responding	Pause	BMC chip does not find.	Board repair
8701	Insufficient Runtime space for MPS data!! System may operate in PIC or Non-MPS mode.	Pause	Failed to copy the MPTable to F000 or E000 shadow RAM.	Board repair
8702	No enough APIC ID in range 0-0Fh can be assigned to IO APICs. (Re-assigning CPUs' local APIC ID may solve this issue) MPS Table is not built! System may operate in PIC or Non-MPS mode.	Pause	Check APIC failed.	Board repair

BMC

Sensor	Sensor Name	Event	Event Log
Sensor Type: Temperature			
41h	NB_TEMP	Threshold – 01h	Lower critical threshold is comparison returned (A, D, S, R) Lower non-critical threshold is comparison returned (A, D, S, R) Upper critical going high (A, D, S, R) Upper non-critical going high (A, D, S, R) A=0280 D=3280 R=1818
40h	MB_TEMP	Threshold – 01h	Lower critical threshold is comparison returned (A, D, S, R) Lower non-critical threshold is comparison returned (A, D, S, R) Upper critical going high (A, D, S, R) Upper non-critical going high (A, D, S, R) A=0280 D=3280 R=1818
44h	CPU0_Temp	Threshold – 01h	Lower critical threshold is comparison returned (A, D, S, R) Lower non-critical threshold is comparison returned (A, D, S, R) Upper critical going high (A, D, S, R) Upper non-critical going high (A, D, S, R) A=0280 D=3280 R=1818

Sensor	Sensor Name	Event	Event Log
Sensor Type: Temperature			
45h	CPU1_Temp	Threshold – 01h	<p>Lower critical threshold is comparison returned (A, D, S, R)</p> <p>Lower non-critical threshold is comparison returned (A, D, S, R)</p> <p>Upper critical going high (A, D, S, R)</p> <p>Upper non-critical going high (A, D, S, R)</p> <p>A=0280 D=3280 R=1818</p>
4Ch	P0_DIMM_TEMP	Threshold – 01h	<p>Lower critical threshold is comparison returned (A, D, S, R)</p> <p>Lower non-critical threshold is comparison returned (A, D, S, R)</p> <p>Upper critical going high (A, D, S, R)</p> <p>Upper non-critical going high (A, D, S, R)</p> <p>A=0280 D=3280 R=1818</p>
4Dh	P1_DIMM_TEMP		
42h	Outlet_TEMP	Threshold – 01h	A=0000 D=0000 R=0000
54h	Chassis_Ambient	Threshold – 01h	<p>Lower critical threshold is comparison returned (A, D, S, R)</p> <p>Lower non-critical threshold is comparison returned (A, D, S, R)</p> <p>Upper critical going high (A, D, S, R)</p> <p>Upper non-critical going high (A, D, S, R)</p> <p>A=0280 D=3280 R=1818</p>

Sensor	Sensor Name	Event	Event Log
Sensor Type: Temperature			
58h	CPU0_PROC_HOT	Digital Discrete	1:State Asserted (A, D, R)
59h	CPU1_PROC_HOT	- 03h	A=0002 D=0000 R=0002
Sensor Type: Watchdog			
D5h	Watchdog	Sensor Specific - 6Fh	0:Timer expired (A, R) 1:Hard Reset (A, R) 2:Power Down (A, R) 3:Power Cycle (A, R) A=000F D=0000 R=000F
Sensor Type: Event Logging			
D0h	EventLog	Sensor Specific – 6Fh	0: Correctable Memory Error Logging Disable 1: Event ‘Type’ Logging Disable 2: Log Area Reset/Cleared 3: All Event Logging Disable 4: SELFull 5: SEL Almost Full A=003f D=0000 R=003f
Sensor Type: Button/Switch			
D4h	Power_Button	Sensor Specific – 6Fh	0:Power Button pressed A=0001D=0000 R=0001
Sensor Type: System Event			
D1h	System Event	Sensor Specific - 6Fh	4:PEF Action (A, R) A=0010 D=0000 R=0010
Sensor Type: Voltage			
10h	CPU0_Vcore	Threshold – 01h	A=0000 D=0000 R=0000
11h	CPU1_Vcore		

Sensor	Sensor Name	Event	Event Log
Sensor Type: Voltage			
12h	DDRP0_Voltage	Threshold - 01h	Lower critical threshold is comparison returned (A, D, S, R)
13h	DDRP1_Voltage		Lower non-critical threshold is comparison returned (A, D, S, R)
			Upper critical going high (A, D, S, R)
			Upper non-critical going high (A, D, S, R)
			Lower critical going low (A, D, S, R)
			Lower non-critical going low (A, D)
			A=3285 D=3285 R=1b1b
28h	P5V	Threshold - 01h	Lower critical threshold is comparison returned (A, D, S, R)
			Lower non-critical threshold is comparison returned (A, D, S, R)
			Upper critical going high (A, D, S, R)
			Upper non-critical going high (A, D, S, R)
			Lower critical going low (A, D, S, R)
			Lower non-critical going low (A, D)
			A=3285 D=3285 R=1b1b

Sensor	Sensor Name	Event	Event Log
Sensor Type: Voltage			
15h	P3V3	Threshold - 01h	<p>Lower critical threshold is comparison returned (A, D, S, R)</p> <p>Lower non-critical threshold is comparison returned (A, D, S, R)</p> <p>Upper critical going high (A, D, S, R)</p> <p>Upper non-critical going high (A, D, S, R)</p> <p>Lower critical going low (A, D, S, R)</p> <p>Lower non-critical going low (A, D)</p> <p>A=3285 D=3285 R=1b1b</p>
Sensor Type: Fan			
6Bh	FCB_FAN1	Threshold - 01h	Lower critical threshold is comparison returned (A, D, S, R)
6Ch	FCB_FAN2		
6Dh	FCB_FAN3		
6Eh	FCB_FAN4		<p>Lower non-critical threshold is comparison returned (A, D, S, R)</p> <p>Lower critical going low (A, D, S, R)</p> <p>Lower non-critical going low (A, D)</p> <p>A=7005 D=7005 R=0303</p>
Sensor Type: Current			
CAh	MB_12V_Current	Threshold - 01h	A=0000 D=0000 R=0000
70h	PSU1_OUT_Current	Threshold -	A=0000 D=0000 R=0000
71h	PSU2_OUT_Current	01h	

Sensor	Sensor Name	Event	Event Log
Sensor Type: Processor			
C0h	CPU0	Sensor Specific – 6Fh	0:IERR
C1h	CPU1		1: Thermal Trip (A,R) 7: Processor Presence detected A=0083 D=0080 R=0083
Sensor Type: Critical Interrupt			
A5h	Critical INT	Sensor Specific - 6Fh	0: Front Panel NMI/DiagnosticInterrupt 1: Bus Timeout 2: I/O channel check NMI 3: Software NMI 4:PCI PERR (A, R) 5:PCI SERR (A, R) 6: EISA Fail Safe Timeout 7: Bus Correctable Error A=003F D=0000 R=003F
Sensor Type: Power Supply			
C9h	PowerUnit	Sensor Specific – 6Fh	0: Presence detected (A,D,R) 1: Power Cycle (A,D,R) 4: AC lost 6: Power Unit Failure detected A=0053 D=0000 R=00053
CBh	PSU1		Sensor Specific – 6Fh
CCh	PSU2		

Sensor	Sensor Name	Event	Event Log
Sensor Type: Memory			
80h	DIMM_A0~	Sensor Specific -	0:Correctable error (A, R)
~	DIMM_A2&	6Fh	1:Uncorrectable error (A, R)
8Bh	DIMM_B0~		A=0003 D=0000 R=0003
	DIMM_B2&		
	DIMM_C0~		
	DIMM_C2&		
	DIMM_D0~		
	DIMM_D2		
Sensor Type: Critical Interrupt			
E3h	PCIE_Error	Sensor Specific -	7: Bus Correctable Error
		6Fh	8: Bus Uncorrectable Error
			A:Bus Fatal Error
			A=0580 D=0000 R=0580
E6h	CPU_Bus_Error	Sensor Specific -	7: Bus Correctable Error
		6Fh	8: Bus Uncorrectable Error
			A=0180 D=0000 R=0180
E7h	SR56X0_Error	Sensor Specific -	7: Bus Correctable Error
		6Fh	8: Bus Uncorrectable Error
			A=0180 D=0000 R=0180

Other Information You May Need



WARNING: See the safety and regulatory information that shipped with your system. Warranty information may be included within this document or as a separate document.

The *Getting Started Guide* provides an overview of rack installation, system features, setting up your system, and technical specifications.



NOTE: Always check for updates on support.dell.com/manuals and read the updates first because they often supersede information in other documents.

Using the System Setup Program

Start Menu

The system employs the latest AMI CMOS BIOS, which is stored in Flash memory. The Flash memory supports the Plug and Play specification, and contains a System Setup program, the Power On Self Test (POST) routine, and the PCI auto-configuration utility.

This system board supports system BIOS shadowing, enabling the BIOS to execute from 64-bit onboard write-protected DRAM.

This Setup utility should be executed under the following conditions:

- When changing the system configuration, configure items such as:
 - Hard drives, diskette drives, and peripherals
 - Password protection from unauthorized use
 - Power management features
- When a configuration error is detected by the system and you are prompted to make changes to the Setup utility
- When redefining the communication ports to prevent any conflicts.
- When changing the password or making other changes to the security setup.



NOTE: Only items in brackets [] can be modified. Items that are not in brackets are display only.

System Setup Options at Boot

<F2>	Initiate Setup during POST
<F9>	Load optimal (e.g. CMOS) defaults
<F10>	Save Settings and exit in BIOS Setup

Console Redirection

The console redirection allows a remote user to diagnose and fix problems on a server, which has not successfully booted the operating system. The centerpiece of the console redirection is the BIOS console. The BIOS Console is a flash memory resident utility that redirects input and output over a serial or modem connection.

The BIOS supports console redirection to a serial port. If the system supports a serial port based server, the system must provide support for redirection of all BIOS driven console I/O to the serial port. The driver for the serial console must be capable of supporting the functionality documented in the ANSI Terminal Definition.

Setting up SOL (Serial Over LAN)

There are two modes of BMC LAN port configuration-Dedicated NIC and Shared NIC to enable Serial Over LAN (SOL) feature. The following steps shows setup process about the LAN connection and BIOS setup settings for Dedicated-NIC and Shared-NIC.

To enable SOL feature in the mode of Dedicated-NIC, please perform the following steps:

- 1 Connect the LAN cable to management port. For location of management port on the back panel, see Figure 1-6 item 7.
- 2 Enter the server BIOS setup screen.

3 Enter Set BMC LAN Configuration screen and verify the following settings:

- Remote Access: enabled
- Serial port number: COM2
- **Serial Port Mode: 115200 8,n,1**
- **Flow Control: None**
- **Redirection After BIOS POST: Always**
- **Terminal Type: ANSI**

To do this, see “Remote Access Configuration” on page 62. Note that the last four options need to sync with the host and client.

4 Enter LAN Configuration screen and verify the following settings:

- BMC LAN Port Configuration: Dedicated-NIC
- DHCP Enabled: Disabled or Enabled (Enabled if DHCP server support)
- **IP Address: 192.168.001.003**
- Subnet Mask: 255.255.255.000
- Gateway Address: 000.000.000.000

To do this, see “LAN Configuration” on page 61. Note that the host and client need to have the same network section.

To enable SOL feature in the mode of Shared-NIC, please perform the following steps:

- 1 Connect the LAN cable to NIC1 connector. For location of NIC1 connector on the back panel, see Figure 1-6 item 5.
- 2 Enter the server BIOS setup screen.
- 3 Enter Set BMC LAN Configuration screen and verify the following settings:
 - Remote Access: enabled
 - Serial port number: COM2
 - **Serial Port Mode: 115200 8,n,1**
 - **Flow Control: None**
 - **Redirection After BIOS POST: Always**
 - **Terminal Type: ANSI**

To do this, see “Remote Access Configuration” on page 62. Note that the last four options need to sync with the host and client.

4 Enter LAN Configuration screen and verify the following settings:

- BMC LAN Port Configuration: Shared-NIC
- DHCP Enabled: Disabled or Enabled (Enabled if DHCP server support)
- **IP Address: 192.168.001.003**
- Subnet Mask: 255.255.255.000
- Gateway Address: 000.000.000.000

To do this, see “LAN Configuration” on page 61. Note that the host and client need to have the same network section.

Main Menu

The main menu displays information about your system boards and BIOS.

Main Screen

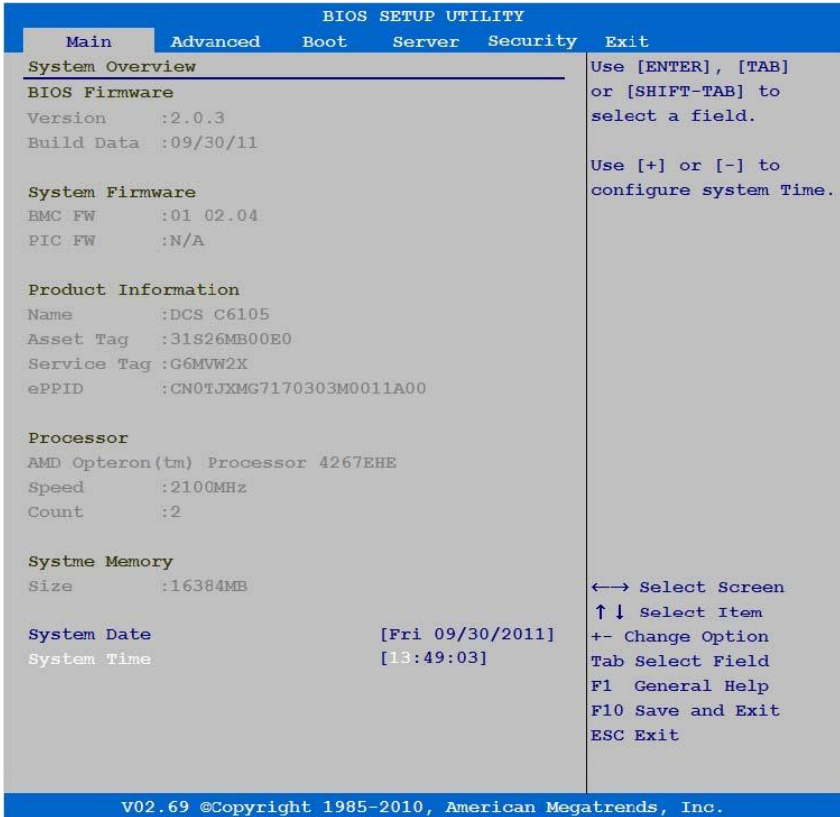



NOTE: The options for the System Setup program change based on the system configuration.



NOTE: The System Setup program defaults are listed under their respective options in the following sections, where applicable.

BIOS Firmware

Option	Description
Version	Displays the BIOS version.
Build Date	Displays the BIOS build date.

System Firmware

Option	Description
BMC FW	Displays the system BMC firmware version.
PIC FW	Displays the system PIC firmware version.

Product Information

Option	Description
Name	Displays the name of the product.
AssetTag	Displays the asset tag of the product.
ServiceTag	Displays the service tag of the product.
ePPID	Displays the eppid of the product.

Processor

Option	Description
Name	Displays the processor name.
Speed	Displays the maximum speed of the processor.
Count	Displays the physical processor count.

System Memory

Option	Description
Size	Displays the total system memory size installed on the system board.
System Date	Displays the current date.
System Time	Displays the current time.

Advanced Menu

This option displays a table of items that defines advanced information about your system.



CAUTION: Making incorrect settings to items on these pages may cause the system to malfunction. Unless you have experience adjusting these items, we recommend that you leave these settings at the default values. If making settings to items on these pages causes your system to malfunction or prevents the system from booting, open BIOS and choose Load Optimal Defaults in the Exit menu to boot up normally.

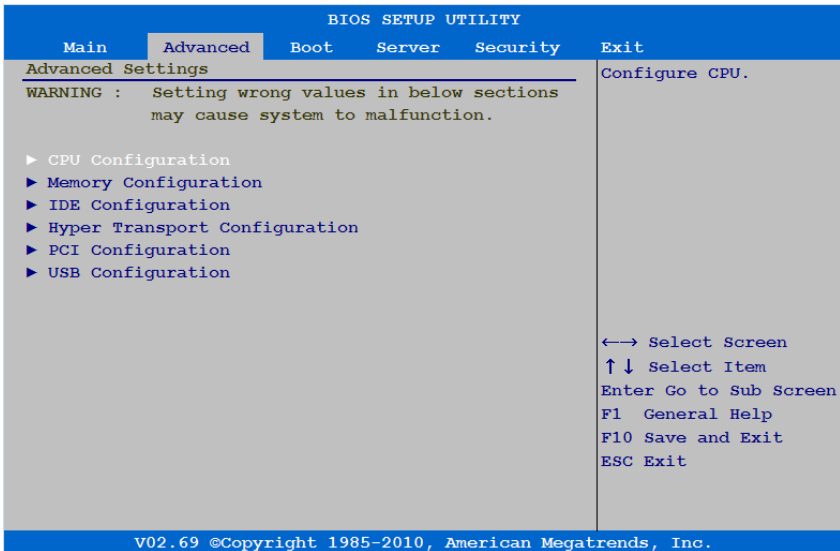

CPU Configuration

Scroll to this item and press **Enter** to view the following screen:

BIOS SETUP UTILITY	
Advanced	
CPU Configuration	Configure Power Management.
Module Version: OrchiPI.1.1.9.0-1	
Socket Count : 2	
Node Count : 2	
Core Count : 16	
<hr/>	
AMD Opteron(tm) Processor 4267EHE	
Revision: B2	
Cache L1: 384KB	
Cache L2: 8192KB	
Cache L3: 8MB	
Speed : 2100MHz, NB Clk 2000MHz	
Able to Change Freq. : Yes	
uCode Patch Level : 0x6000613	
▶ Power Management	
GART Error Report	[Disabled]
Secure Virtual Machine Mode	[Enabled]
IOMMU	[Disabled]
SR-IOV	[Disabled]
ACPI SRAT Table	[Enabled]
L3 Power Control	[Enabled]
Prob filter Mode	[Auto]
DRAM Prefetcher	[Enabled]
Hardware Prefetcher	[Enabled]
HW Prefetch Training on SW	[Enabled]
CPB Mode	[Auto]
C1E support	[Enable]
TDP Control	[Auto]
Node TDP Limit	[Enabled]
APML SW TDP Limit	[Enabled]
	←→ Select Screen
	↑↓ Select Item
	Enter Go to Sub Screen
	F1 General Help
	F10 Save and Exit
	ESC Exit
V02.69 ©Copyright 1985-2010, American Megatrends, Inc.	

Option	Description
Module Version	Displays the current processor module version.
Socket Count	Displays the processor socket count.
Node Count	Displays the node count.
Core Count	Displays the processor core count.
Revision	Displays the processor version.
Cache L1	Displays the size of CPU L1.
Cache L2	Displays the size of CPU L2.
Cache L3	Displays the size of CPU L3.
Speed	Displays the frequency of CPU.
Able to change Freq.	Displays the capable of frequency change.
uCode Patch Level	Displays the ucode patch level.
Power Management	Configures Power Management.
GART Error Report (Disabled default)	This option should remain disabled for the normal operation. The driver developer may enable it for testing purpose.
Secure Virtual Machine Mode (Enabled default)	Selects this item to enable or disable the function of securing virtual machine mode (SVM).
IOMMU (Disabled default)	Selects this item to enable or disable the IOMMU device. For Linux Certification, IOMMU needs to be enabled and XEN must be installed.
SR-IOV (Disabled default)	Enable/Disable Single Root I/O Virtualization.
ACPI SRAT Table (Enabled default)	Selects this item to enable or disable the building of ACPI SRAT table.
L3 Power Control (Enabled default)	Selects Enabled to stop the clock of idle sub-caches in the L3.

Option	Description
Probe Filter Mode (Auto default)	Selects Auto or Disabled to probe filter mode on or off.
DRAM Prefetcher (Enabled default)	Selects Disabled to prevent the DRAM references from triggering DRAM prefetch requests. Selects Enabled to turn on the DRAM prefetch unit in the Northbridge.
Hardware Prefetcher (Enabled default)	Selects this item to enable or disable the Hardware Prefetcher.
HW Prefetch Training on SW (Enabled default)	Hardware Prefetch Training on Software Prefetch Disabled: Prevent hardware prefetcher from considering software prefetches when detecting strides for prefetch. Enabled: Hardware prefetcher considers software prefetches when detecting strides for prefetch requests.
CPB Mode (Auto default)	Specifies the method of core performance boost enablement. This option only support on Valencia processor. This option only support on 3BXX/2.x.x.BIOS.
C1E Support (Enabled default)	Configures C1E type. Set auto to use Message-Triggered if support by hardware. This option only support on 3BXX/2.x.x.BIOS.
TDP Control (Auto default)	Configure TDP Control Setting.
Node TDP Limit (Enabled default)	Configure Node TDP Limit. This setting only can be seen when “TDP Control” be selected to “Manual” mode.
APML SW TDP Limit (Enabled default)	Configure APML SW TDP Limit. This setting only can be seen when “TDP Control” be selected to “Manual” mode.

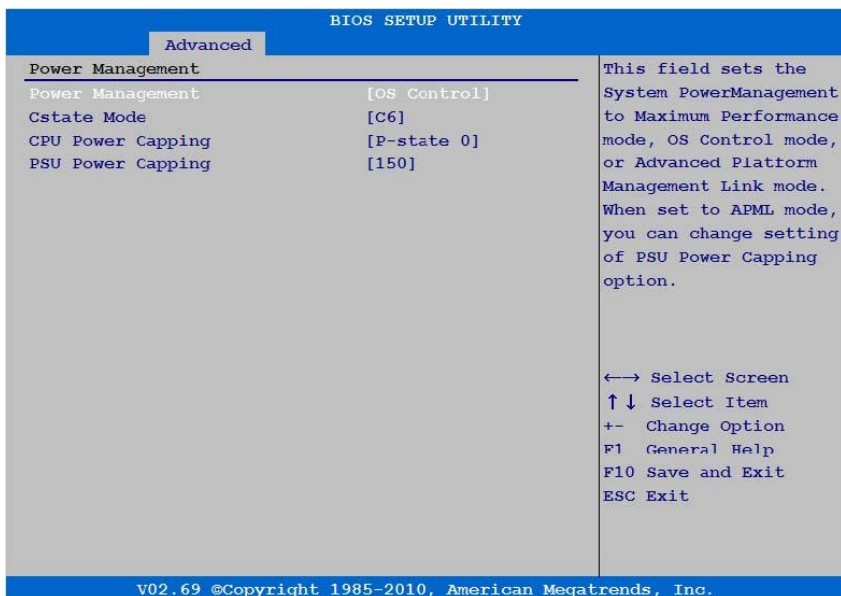

Option	Description
Power Management (OS Control default)	This field sets the System Power Management to Maximum Performance mode, OS Control mode, or Advanced Platform Management Link mode. When set to APML mode, you can change setting of PSU Power Capping options.
Cstate Mode (C6 default)	Specifies the method of C-State enablement. 16MB memory is use to hold the state information of cores entering the CC6 power management state. This option only support on Valencia processor. This option only support on 3BXX/2.x.x.BIOS.

Option	Description
CPU Power Capping (P-state 0 default)	This option can decide the highest performance P-state in OS. This setting only can be seen when “Power Management” be selected to “OS Control” mode.
PSU Power Capping (150 default)	The setting controls PSU Power, its range limited in 150~2000W. The value is sent to BMC by IPMI command and BMC controls PSU power. This setting only can be seen when “Power Management” be selected to “APML” mode and the system board at location 4 in the chassis.

Memory Configuration

Scroll to this item and press **Enter** to view the following screen:

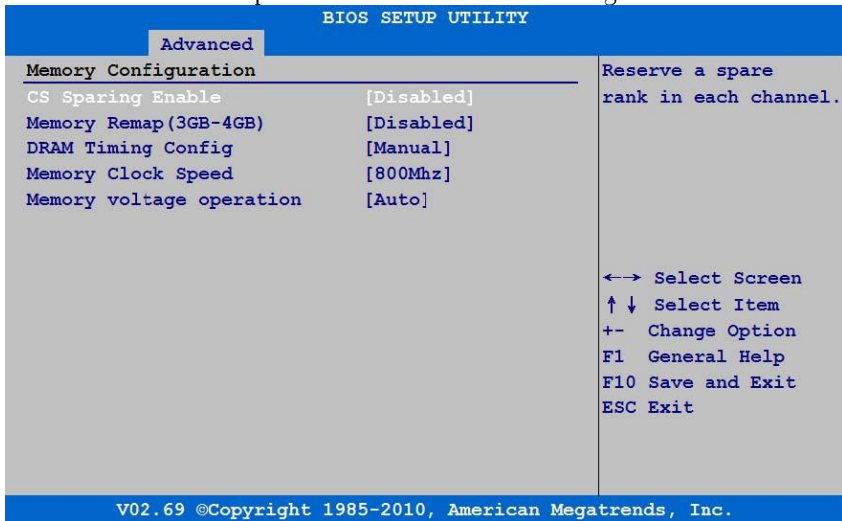

Option	Description
CS Sparing Enable (Disabled default)	Reserve a spare memory rank in each channel.
Memory Remap (3GB-4GB) (Disabled default)	Enable remap system memory space 3GB-4GB.
DRAM Timing Config	Controls the DRAM frequency.
Memory Clock Speed	Memory clock setting, items 800/1066/1333 may not show all, it will base on memory configuration to display valid selections. This setting can only be seen when “DRAM Timing Config” is selected to “Manual”.
Memory voltage operation (Auto default)	Enable this option for low-voltage memory module only. This setting can only be seen when LV-DIMMs are used.

SATA Configuration

Scroll to this item and press **Enter** to view the following screen:

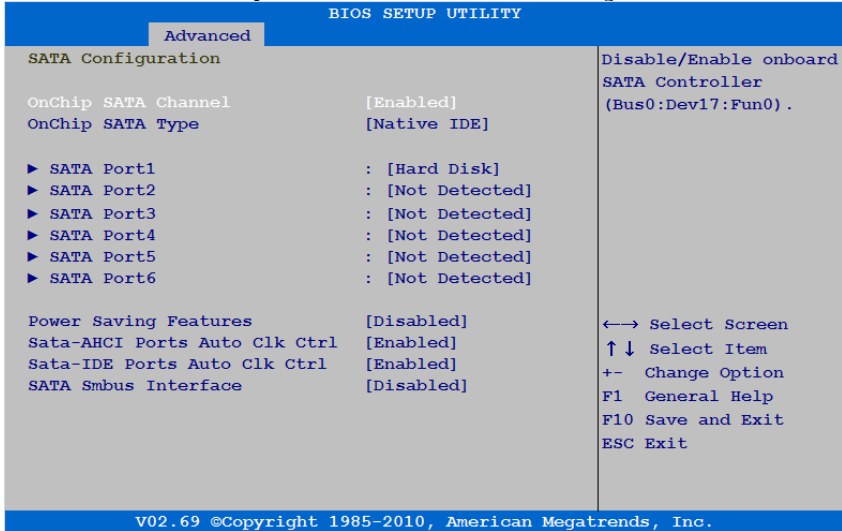

Option	Description
OnChip SATA Channel (Enabled default)	Selects this item to enable or disable Onboard SATA controller.
OnChip SATA Type (Native IDE default)	Native IDE: Native mode. AMD_AHCI: Use AMD AHCI option ROM. IDE->AMD_AHCI: No AHCI option ROM, use AMD AHCI driver (need load driver during the operating system installation, Windows 2008 R2 had native support.)
SATA Port1~6	While entering SATA setup, BIOS auto-detects the presence of SATA devices and displays the status of detected SATA hard drives.
Power Saving features (Disabled default)	Selects this item to enable or disable power saving features in SB.

Option	Description
SATA-AHCI Ports Auto Clk Ctrl (Enabled default)	This option disables the clocks for unused SATA ports in AHCI modes. This will enable some power savings. But please note that if you shutdown the clock, then hot-plug for that port will not work.
SATA-IDE Ports Auto Clk Ctrl (Enabled default)	This option disables the clocks for unused SATA ports in IDE modes. It will enable some power savings. But please note that if you shut clock, then hot - plug for that port will not work.
SATA Smbus Interface (Disabled default)	Enable or disable SATA SMBUS Interface. SATA controller contains a smbus slave controller which can be used to program the SATA PHY circuitry. This is used for testing/characterization purpose.

Select SATA Port 1-6 to configure each device on the SATA channel using the following screen:

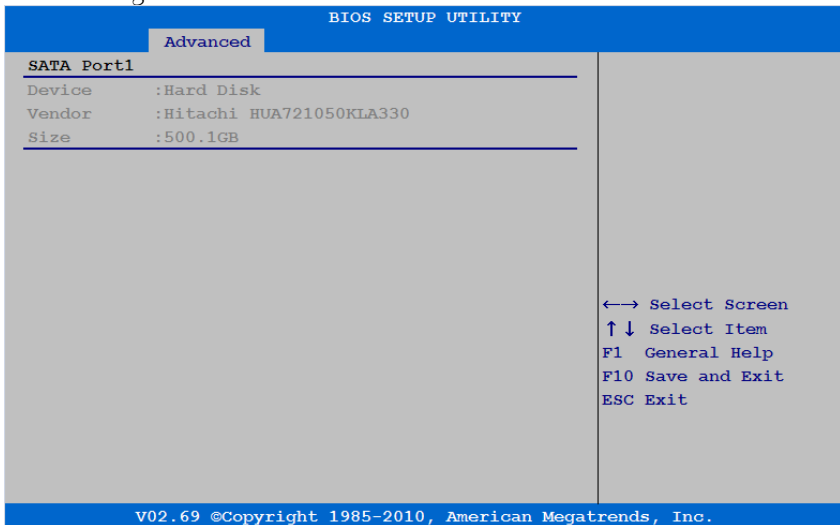

Option	Description
Device	Displays the type of device assigned to this channel.
Vendor	Displays the manufacture's name of the device.
Size	Displays the size of the device (GB).

Hyper Transport Configuration

Scroll to this item and press **Enter** to view the following screen:

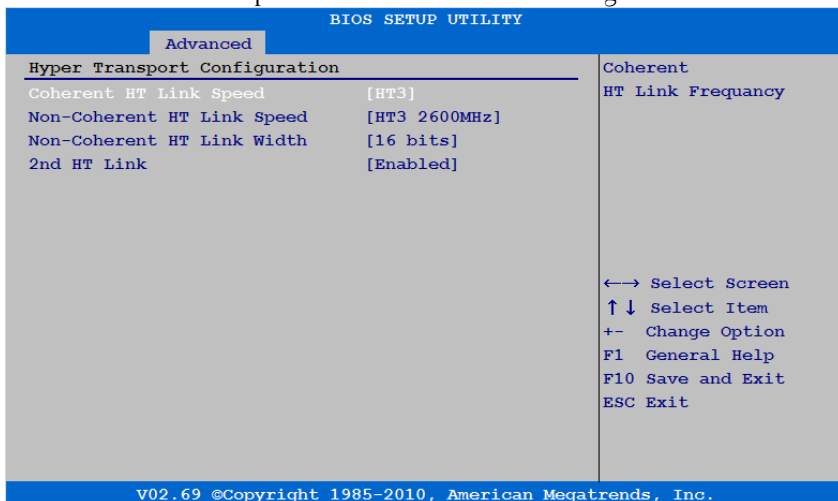

Option	Description
Coherent HT Link Speed (HT3 default)	Selects coherent HT link frequency.
Non-Coherent HT Link Speed (HT3 2600MHz default)	This option is to set Non-Coherent HT Link frequency and based on the processor core number displays different selections. For 4 core processor: HT1 800/1000, HT3 1200/1600/2000/2600 For 6 core processor: HT3 1200/1600/2000/2600

Option	Description
Non-Coherent HT Link Width (16bits default)	Selects non-coherent HT link width.
2nd HT Link (Enabled default)	Selects this item to enable or disable the 2nd HT link between socket 0 and socket 1.

PCI Configuration

Scroll to this item and press **Enter** to view the following screen:

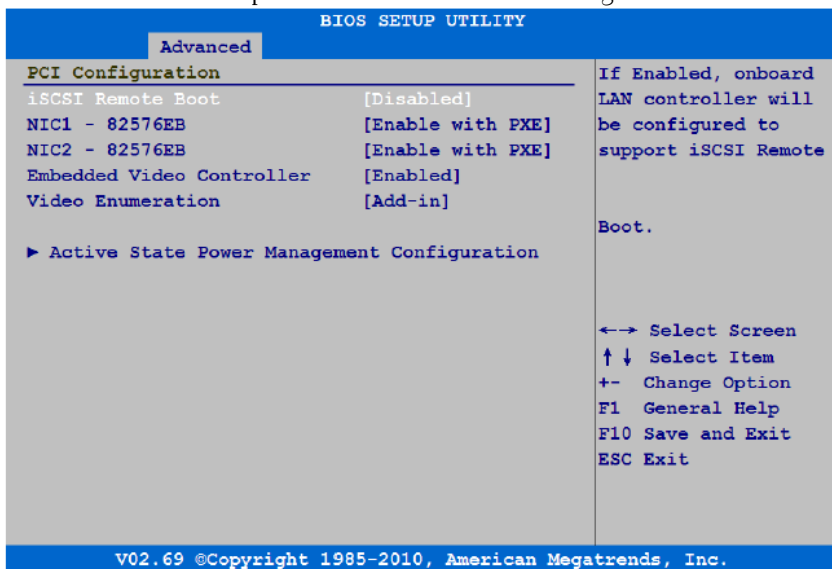

Option	Description
iSCSI Remote Boot (Disabled default)	If Enabled, onboard LAN controller is configured to support iSCSI Remote Boot.
NIC1-82576EB (Enable without PXE default)	Selects this item to enable or disable onboard NIC1 controller and PXE support. This item only can be seen if “iSCSI Remote Boot” is Disabled.

Option	Description
NIC2-82576EB (Enable without PXE default)	Selects this item to enable or disable onboard NIC2 controller and PXE support. This item only can be seen if “iSCSI Remote Boot” is Disabled.
Embedded Video Controller	Selects this item to enable or disable the embedded video controller.
Video Enumeration	Choose the onboard or the first add-in video controller for boot-time message.
Active State Power Management Configuration	To control Active State Power Management (ASPM).

USB Configuration

Scroll to this item and press **Enter** to view the following screen:

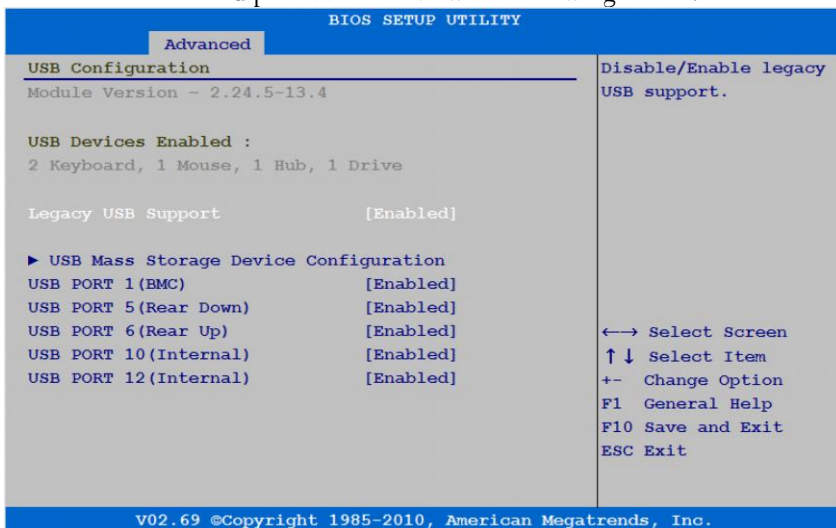

Option	Description
Module Version	Displays the module version.
USB Devices Enabled	Displays USB devices currently detected.

Option	Description
Legacy USB Support (Enabled default)	Disable/enable legacy USB support.
USB Port 1(BMC) (Enabled default)	Enable or disable the corresponding USB port.
USB Port 5 (Rear Down) (Enabled default)	Enable or disable the corresponding USB port.
USB Port 6 (Rear Up) (Enabled default)	Enable or disable the corresponding USB port.
USB Port 10 (Internal) (Enabled default)	Enable or disable the corresponding USB port.
USB Port 12 (Internal) (Enabled default)	Enable or disable the corresponding USB port.

Boot Menu

This page enables you to set POST boot parameters.

Scroll to this item and press **Enter** to view the following screen:

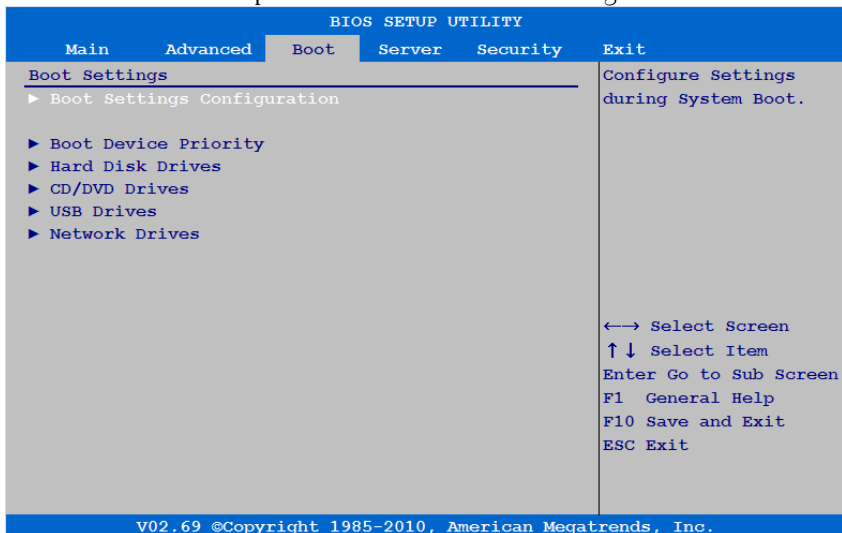

Option	Description
Boot Settings Configuration	Configures the settings during system boots.
Boot Device Priority	Specifies the boot device priority sequence.
Hard Disk Drives	Specifies the boot device priority sequence from the available hard drives. This item only can be seen when system have bootable Hard Disk Drives.
CD/DVD Drives	Specifies the boot device priority sequence from available CD/DVD Drives. This item only can be seen when system have bootable CD/DVD Drives.
USB Drives	Specifies the boot device priority sequence from available USB Drives. This item only can be seen when system have bootable USB Drives.
Network Drives	Specifies the boot device priority sequence from available Network Drives. This item only can be seen when system have bootable Network Drives (PXE).

Boot Settings Configuration

Select this item and press **Enter** to view the following submenu items:

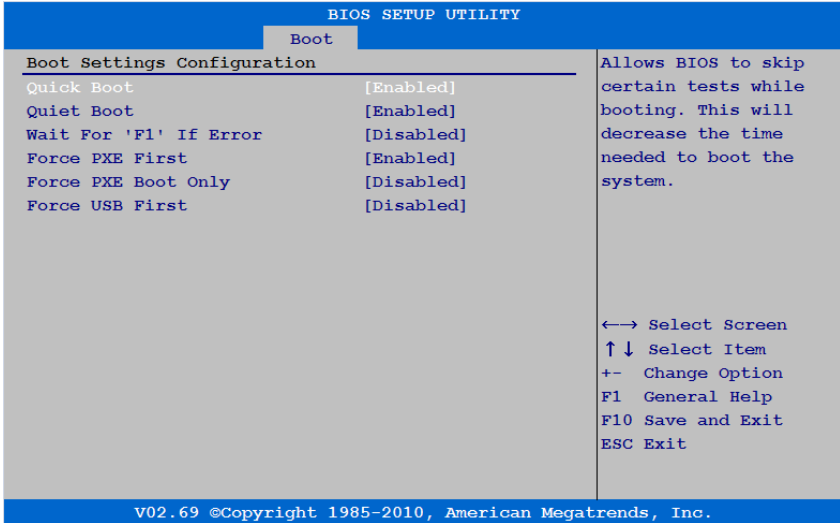

Option	Description
Quick Boot (Enabled default)	Allow BIOS to skip certain tests while booting, which will decrease the time needed to boot the system.
Quiet Boot (Enabled default)	Disabled: displays normal POST messages. Enabled: displays OEM logo instead of POST messages.
Wait For 'F1' if Error (Disabled default)	Wait for F1 key to be pressed if error occurs.
Force PXE First (Enabled default)	Enables or disables PXE to be the first boot device. It will take effect on the next boot.
Force PXE Boot Only (Disabled default)	Enables or disables PXE to be the Only boot device.
Force USB First (Disabled default)	Enable or disable USB to be the first boot device, the priority is higher than PXE. It will take effect on the next boot.

Boot Device Priority

Select this item and press **Enter** to view the following submenu items:

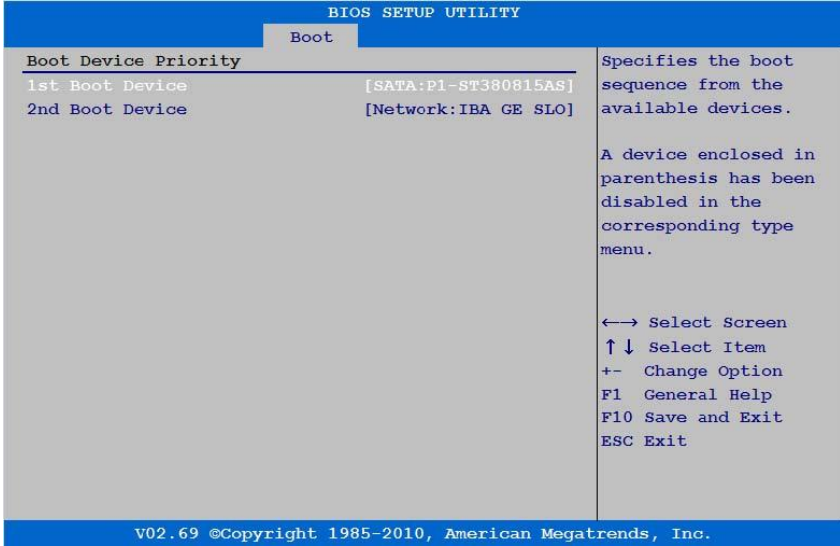

The screenshot shows the BIOS Setup Utility interface. At the top, it says "BIOS SETUP UTILITY" and "Boot". The main menu is titled "Boot Device Priority" and lists two items: "1st Boot Device" with the value "[SATA:P1-ST380815AS]" and "2nd Boot Device" with the value "[Network:IBA GE SLO]". To the right of the menu, there is a description: "Specifies the boot sequence from the available devices. A device enclosed in parenthesis has been disabled in the corresponding type menu." Below the description, there are navigation instructions: "←→ Select Screen", "↑↓ Select Item", "+- Change Option", "F1 General Help", "F10 Save and Exit", and "ESC Exit". At the bottom of the screen, it says "V02.69 ©Copyright 1985-2010, American Megatrends, Inc."

BIOS SETUP UTILITY	
Boot	
Boot Device Priority	
1st Boot Device	[SATA:P1-ST380815AS]
2nd Boot Device	[Network:IBA GE SLO]

Specifies the boot sequence from the available devices.

A device enclosed in parenthesis has been disabled in the corresponding type menu.

←→ Select Screen
↑↓ Select Item
+- Change Option
F1 General Help
F10 Save and Exit
ESC Exit

V02.69 ©Copyright 1985-2010, American Megatrends, Inc.

Server Menu

This page enables you to configure Server parameters. Scroll to this item and press **Enter** to view the following screen:

BIOS SETUP UTILITY					
Main	Advanced	Boot	Server	Security	Exit
Server Configuration				InPut for Set LAN Configuration command. See IPMI 2.0 Spec, table 23-1.	
Status of BMC		Working			NOTE: Each question in this group may take considerable amount of time. ←→ Select Screen ↑↓ Select Item Enter Go to Sub Screen +/- Change Option F1 General Help F10 Save and Exit ESC Exit
IPMI Specification Version		2.0			
BMC Firmware Version		01 01.04			
PIC Firmware Version		N/A			
NIC1 MAC Address		[00-23-8B-DF-C1-60]			
NIC2 MAC Address		[00-23-8B-DF-C1-61]			
▶ Set BMC LAN Configuration					
▶ Remote Access Configuration					
Restore on AC Power Loss		[Power On]			
Power Staggering AC Recovery		[User Defined]			
Power On Delay		[0]			
Minimum Power On Delay : 00000					
Maximum Power On Delay : 00255					
Event Control Interface					
▶ View BMC System Event Log					
Clear BMC System Event Log					
Event Logging [Enabled]					
NMI on Error [Disabled]					
V02.69 ©Copyright 1985-2010, American Megatrends, Inc.					

Option	Description
Status of BMC	Displays the BMC status.
IPMI Specification Version	Displays the IPMI specification version.
BMC Firmware Version	Displays the BMC firmware version.
PIC Firmware Version	Displays the PIC firmware version.
NIC1 MAC Address	Displays the NIC1 MAC address.
NIC2 MAC Address	Displays the NIC2 MAC address.

Option	Description
Set BMC LAN Configuration	Inputs for Set LAN Configuration command. Each item in this group may take considerable amount of time.
Remote Access Configuration	Configures Remote Access.
Restore on AC Power Loss (Power Off default)	System action to take on AC power loss recovery.
Power Staggering AC Recovery (Immediate default)	Configures power recovery behavior. This item only can be seen when “Remote on AC Power Loss” be selected in “Power On” or “Last State”.
Power On Delay (user defined)	Configures time for power on delay, the setting range of delay time is 0~255sec.
View BMC System Event Log	View all events in the BMC Event Log. It will take a max. of 15 seconds to read all BMC SEL records.
Clear BMC System Event Log	Clears all events in the BMC Event Log.
Event Logging (Enabled default)	Enables or disables BIOS to log system events to BMC, errors include ECC/PCI/PCI-E/HT...etc.
NMI on Error (Disabled default)	Enables or disables BIOS to generate NMI when uncorrectable errors occur.

LAN Configuration

Select Set BMC LAN Configuration to view the following submenu:

BIOS SETUP UTILITY					
Main	Advanced	Boot	Server	Security	Exit
LAN Configuration					Set BMC LAN Port to Dedicated-NIC or Shared-NIC. ←→ Select Screen ↑↓ Select Item +/- Change Option F1 General Help F10 Save and Exit ESC Exit
Channel Number			[01]		
Channel Number Status:			Channel number is OK		
BMC LAN Port Configuration			[Shared-NIC]		
DHCP Enabled			[Enabled]		
IP Address			[192.168.001.002]		
Subnet Mask			[255.255.255.000]		
GateWay Address			[192.168.001.001]		
Current Mac address in BMC:			CB.0A.A9.9D.FE.8F		
V02.69 ©Copyright 1985-2010, American Megatrends, Inc.					

Option	Description
Channel Number	Displays the channel number.
Channel Number Status	Displays the channel number status.
BMC LAN Port Configuration (Shared-NIC default)	Sets BMC LAN Port to dedicated-NIC or shared-NIC (Port 1 is defaulted as shared NIC).
DHCP Enabled (Enabled default)	Enables or disables BMC LAN to get LAN IP from DHCP.
IP Address (Input by user)	Uses this screen to input IP address.
Subnet Mask (Input by user)	Uses this screen to input subnet mask address.
Gateway Address (Input by user)	Uses this screen to input Gateway address.
Current Mac address in BMC	Displays the current Mac address in BMC.

Remote Access Configuration

Select Remote Access Configuration to view the following submenu:

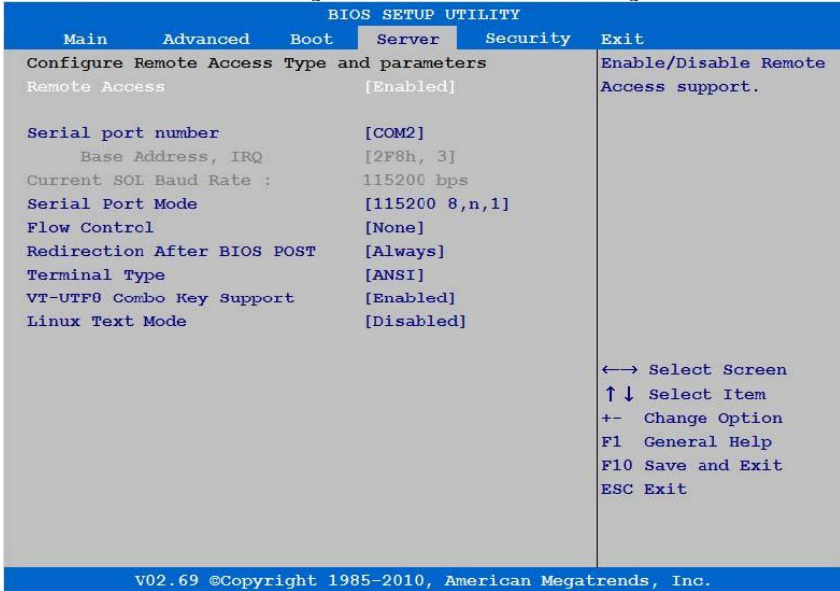

Option	Description
Remote Access (Enabled default)	Enables or disables remote access support.
Serial Port Number (COM2 default)	Selects serial port for console redirection.
Serial Port Mode (115200 8,n,1 default)	Selects serial port settings.
Flow Control (None default)	Selects flow control for console redirection.
Redirection After BIOS POST (Always default)	Disabled: turn off the redirection after POST. Always: Redirection is always active. (Some Oss may not work if set to Always.)

Option	Description
Terminal Type (ANSI default)	Selects the target terminal type.
VT-UTF8 Combo Key Support (Enabled default)	Enables or disables VT-UTF8 combination key support for ANSI/VT100 terminals.
Linux Text Mode (Disabled default)	Enable to support Linux Text Mode.

View BMC System Event Log

Select this item to view the following submenu:

```

BIOS SETUP UTILITY
  Server
-----
Total Number Of Entries:          60
SEL Entry Number                  [1]
SEL Record ID:                    0001
SEL Record Type                   02 (System Event)
Event Timestamp:                  12s from SEL init
Generator ID:                     0020
Event Message Format Ver:         04 (IPMI ver 2.0)
Event Sensor Type:                02 (Voltage)
Event Sensor Number:              12
Event Dir Type:                   01
Event Data:                        57 C3 1D
- Upper Non-critical - going high
- N/A
- N/A

Use +/- to traverse the event log.

<--> Select Screen
↑↓ Select Item
+- Change Option
F1 General Help
F10 Save and Exit
ESC Exit

V02.69 ©Copyright 1985-2010, American Megatrends, Inc.

```

Security Menu

This page enables you to set the security parameters. Scroll to this item and press **Enter** to view the following screen:

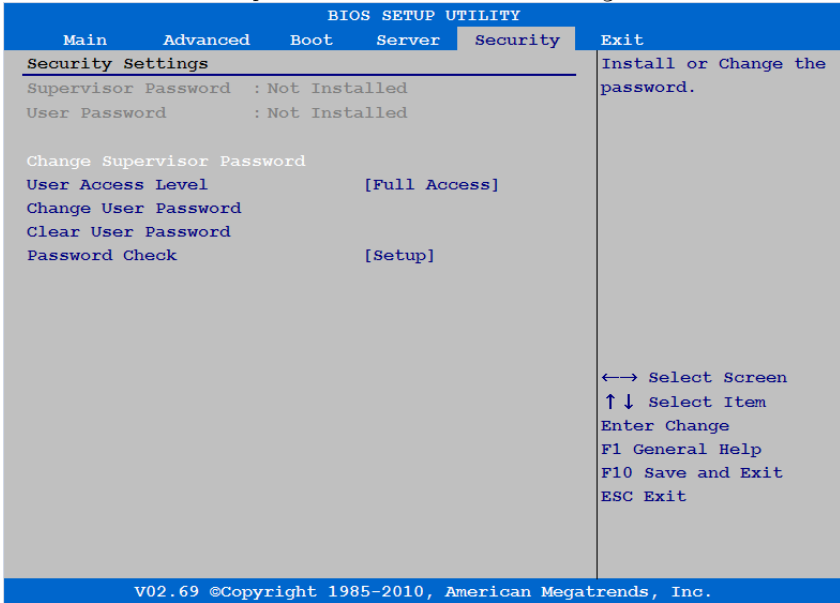

Option	Description
Supervisor Password	Displays whether the supervisor password is installed or not.
User Password	Displays whether the user password is installed or not.
Change Supervisor Password	Installs or changes the password.
User Access Level (Full Access default)	Limited: allows only limited fields to be changed such as Date and Time. No Access: prevents User access to the Setup Utility. View Only: allows access to the Setup Utility but the fields cannot be changed. This item only can be seen when the Supervisor password is installed.

Option	Description
Change User Password	Installs or changes the password.
Clear User Password	Immediately clears the User password. This item only can be seen when the user password is installed.
Password Check (Setup default)	Setup: Check password while invoking setup. Always: Check password while invoking setup as well as on each boot. This item only can be seen when the supervisor or the user password is installed.

Exit Menu

Scroll to this item and press **Enter** to view the following screen:

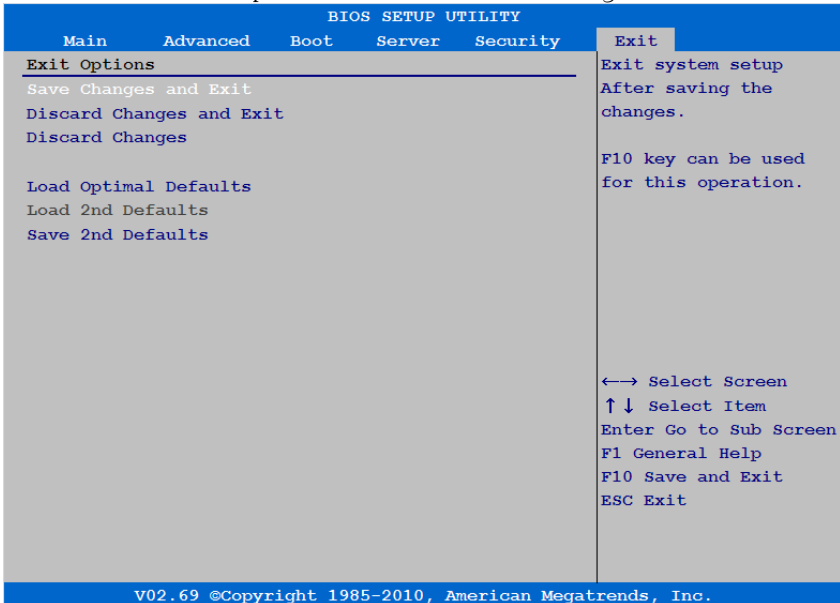

Option	Description
Save Changes and Exit	Exit system setup after saving the changes. F10 key can be used for this operation.
Discard Changes and Exit	Exit system setup without saving any changes. ESC key can be used for this operation.
Discard Changes	Discards changes done so far to any of the setup questions. F7 key can be used for this operation.
Load Optimal Defaults	Load optimal default values for all the setup questions. F9 key can be used for this operation.
Load 2nd Defaults	Load second default values for all the setup questions. This item only selectable if 2nd Defaults was saved before. The first time to save 2nd Default in setup, the item will not be displayed immediately, only available from the next boot.
Save 2nd Defaults	Save all setup questions' current value as second default.

Command Line Interfaces for Setup options

The options of SETUP menu allow the user to control by system configuration utility (syscfg), the utility includes in Dell OpenManage Deployment Toolkit (DTK).

Users can use the utility as following:

- To change the SETUP option by D4 token:
./syscfg -t=D4_token_id

(Example: ./syscfg -t=0x002D to enable NIC1)

- To check token active status:
`./syscfg --istokenactive=D4_token_id`
 (Example: `./syscfg --istokenactive=0x002D` to check the token active status of NIC1)
- To change the SETUP option thru BMC memory directly:
`./ipmitool raw <command> <data>`
 (Example: `./ipmitool raw 0xc 1 1 3 10 106 42 120` to set IP address of BMC LAN port as 10.106.42.120)

The D4 token table

Token	Setup option	Description
002D	NIC1 - 82576	Enable the system's primary embedded network interface controller (full-function), including its PXE boot-ROM.
002E	NIC1 - 82576	Disable the system's primary embedded network interface controller.
006E	NIC1 - 82576	Enable the system's primary embedded network interface controller, but don't enable the NIC's associated PXE or RPL boot-ROM.
0051	1st Boot Device	Set the diskette device to be inserted as the first device in the boot sequence.
0052	1st Boot Device	Only the hard drive can be in the boot sequence
0053	1st Boot Device	Boot seq device list.
0054	1st Boot Device	Set the CDROM to be inserted as the first device in the boot sequence.
0087	Video Enumeration	The onboard video controller is used for boot-time messages.
0088	Video Enumeration	The first add-in video controller is used for boot-time messages. Depending on the BIOS search order and system slot layout.
00A1	Restore on AC Power Loss	After an AC power loss, when AC power is restored, the system stays off.

Token	Setup option	Description
00A2	Restore on AC Power Loss	After an AC power loss, when AC power is restored, the system returns to the state was in when power was lost.
00A3	Restore on AC Power Loss	After an AC power loss, when AC power is restored, the system powers on.
00BA	NIC2 - 82576	Disable the system's secondary embedded network interface controller.
00BB	NIC2 - 82576	Enable the system's secondary embedded network interface controller, but don't enable the NIC's associated PXE or RPL boot-ROM.
00BC	NIC2 - 82576	Enable the system's secondary embedded network interface controller (full-function), including its PXE boot-ROM.
00BF	Remote Access	Serial Console Redirection Off.
00C0	Serial port number	Serial Console Redirection On, output to COM1. See also token D7h.
00D7	Serial port number	Console redirection ON - on COM2.
00D8	Load Optimal Defaults	Enable load CMOS optimal.
00D9	None	Disable load CMOS optimal.
00FE	Legacy USB Support	Disables support for legacy USB.
00FF	Legacy USB Support	Enables support for legacy USB.
0137	OnChip SATA Type	Onboard SATA controller(s) is set to Native IDE mode.
0138	OnChip SATA Type	Onboard SATA controller(s) is set to IDE->AMD_AHCI mode.
0139	OnChip SATA Type	Onboard SATA controller(s) is set to AMD_AHCI mode.
0224	Embedded Video Controller	Enable embedded video controller.

Token	Setup option	Description
0225	Embedded Video Controller	Disable embedded video controller.
024D	Wait For 'F1' If Error	Enabled the BIOS from prompting for F1/F2 on error. BIOS pauses at F1/F2 prompt.
024E	Wait For 'F1' If Error	Disabled the BIOS from prompting for F1/F2 on error. BIOS pauses at F1/F2 prompt.
024F	Quiet Boot	Enables the display of the splash or summary screen, rather than the detail of the POST flow.
0250	Quiet Boot	Disabled the display of the splash or summary screen. The user is able to see the detail of the POST messages.
0251	Network Drives/1st Drive	The first NIC is used for PXE boot, followed by NIC2.
0252	Network Drives/1st Drive	The second NIC is used for PXE boot, followed by NIC1.
02B6	Memory voltage operation	Set memory voltage to 1.5v.
02B7	Memory voltage operation	Set memory voltage to 1.35v.
02B8	Memory voltage operation	Auto detect memory voltage.
4019	Terminal Type	The BIOS console redirection, if enabled, operates in VTUTF8 emulation model. See also tokens BFh, C0h, and D7h.
401A	Terminal Type	The BIOS console redirection, if enabled, operates in VT100 emulation model. See also tokens BFh, C0h, and D7h.
401B	Terminal Type	The BIOS console redirection, if enabled, operates in ANSI emulation model. See also tokens BFh, C0h, and D7h.
401C	Redirection After BIOS POST	The BIOS console redirection, if enabled, continues to operate after the OS boot hand-off.

Token	Setup option	Description
401D	Redirection After BIOS POST	The BIOS console redirection, if enabled, operates during the BIOS boot only and is disabled prior to OS boot hand-off. See also tokens BFh, C0h, D7h, 401Ah and 401Bh.
4022	Force PXE first	Whenever the BIOS boots up the system, the first PXE-capable device is inserted as the first device in the boot sequence. Enabling this feature causes the BIOS operation to occur on the next and all subsequent boots and causes a change in the system's defined boot sequence (unlike tokens 93h and 94h). The BIOS chooses the first PXE-capable device as the system's onboard network controller, if present and enabled, or the first bootable network device found in the system's standard PCI search order — whichever comes first.
4023	Force PXE first	The PXE boot override is disabled and the system boot sequence is in effect.
4033	Serial Port Mode	Console Redirection baud rate is set to 115,200 bits per second.
4034	Serial Port Mode	Console Redirection baud rate is be set to 57,600 bits per second.
4035	Serial Port Mode	Console Redirection baud rate is set to 19,200 bits per second.
4036	Serial Port Mode	Console Redirection baud rate is set to 9,600 bits per second.
4037	Serial Port Mode	Console Redirection baud rate is set to 3,840 bits per second.
4800	Quick Boot	Do not allows BIOS to skip certain tests while booting.
4801	Quick Boot	Allows BIOS to skip certain tests while booting. This decreases the time needed to boot the system.
4804	SR-IOV	Disable Single Root I/O Virtualization.
4805	SR-IOV	Enable Single Root I/O Virtualization.
480E	BMC LAN Port	Specifies the current mode of operation for the BMC

Token	Setup option	Description
	Configuration	network interface to Dedicated-Nic.
480F	BMC LAN Port Configuration	Specifies the current mode of operation for the BMC network interface to Shared-Nic.
4810	DHCP Enabled	Disable to get BMC IP address through DHCP server.
4811	DHCP Enabled	Enable to get BMC IP address through DHCP server.
4816	Force PXE Boot only	Enable PXE to be the Only boot.
4817	Force PXE Boot only	Disable PXE to be the Only boot.
4838	Flow Control	Remote access flow control by none.
4839	Flow Control	Remote access flow control by hardware.
483A	Flow Control	Remote access flow control by Software.
4840	Force USB first	Disable USB to be the first boot device.
4841	Force USB first	Enable USB to be the first boot device, the priority is higher than PXE. It takes effect on next boot.
4842	iSCSI Remote Boot	
4843	iSCSI Remote Boot	Config Onboard Lan to iSCSI.
4850	GART Error Report	Disable GART Error report. This option should remain disabled for the normal operation. The driver developer may enable it for testing purpose.
4851	GART Error Report	Enable GART Error report. This option should remain disabled for the normal operation. The driver developer may enable it for testing purpose.
4854	Secure Virtual Machine Mode	Disable Secure Virtual Machine Mode.
4855	Secure Virtual Machine Mode	Enable Secure Virtual Machine Mode.
4858	ACPI SRAT Table	Disable the building of ACPI SRAT Table. When this option is Disabled, NUMA is not supported.
4859	ACPI SRAT Table	Enable the building of ACPI SRAT Table. When this option is Enabled, NUMA is supported.

Token	Setup option	Description
4860	CPU Power Capping	To decide the highest performance P-state in OS. (P0-state)
4861	CPU Power Capping	To decide the highest performance P-state in OS. (P1-state)
4862	CPU Power Capping	To decide the highest performance P-state in OS. (P2-state)
4863	CPU Power Capping	To decide the highest performance P-state in OS. (P3-state)
4864	CPU Power Capping	To decide the highest performance P-state in OS. (P4-state)
4865	OnChip SATA Channel	Disabled all SATA channel on board.
4866	OnChip SATA Channel	Enabled all SATA channel on board.
4871	Sata-AHCI Ports Auto Clk Ctrl	This option when enabled shuts down the clocks for unused SATA ports in AHCI and AMD_AHCI modes. This will enable some power savings. Note: If you shutdown clock, then hotplug for that port will not work.
4872	Sata-AHCI Ports Auto Clk Ctrl	This option when enabled shuts down the clocks for unused SATA ports in AHCI and AMD_AHCI modes. This will enable some power savings. Note: If you shutdown clock, then hotplug for that port will not work.

Token	Setup option	Description
4873	Sata-IDE Ports Auto Clk Ctrl	This option when enabled shuts down the clocks for unused SATA ports in IDE modes, IDE->AHCI, IDE->AMD_ACHI modes. This will enable some power savings. Note: If you shutdown clock, then hotplug for that port will not work.
4874	Sata-IDE Ports Auto Clk Ctrl	This option when enabled shuts down the clocks for unused SATA ports in IDE modes, IDE->AHCI, IDE->AMD_ACHI modes. This will enable some power savings. Note: If you shutdown clock, then hotplug for that port will not work.
4875	SATA Smbus Interface	Disabled SATA Smbus interface.
4876	SATA Smbus Interface	Enabled SATA Smbus interface.
4877	Coherent HT Link Speed	Coherent HT Link Speed HT1.
4878	Coherent HT Link Speed	Coherent HT Link Speed HT3.
4881	2nd HT Link	Disable the 2nd HT Link between Socket0 and Socket1.
4882	2nd HT Link	Enabled the 2nd HT Link between Socket0 and Socket1.
4883	NB-SB Link ASPM	Controls the level of ASPM supported on the NB-SB. All entry disabled
4884	NB-SB Link ASPM	Controls the level of ASPM supported on the NB-SB. L1 entry enabled.
4887	L3 Power Control	The clock to idle subcaches in the L3 is not stopped.
4888	L3 Power Control	The clock to idle subcaches in the L3 is stopped.

Token	Setup option	Description
4891	Power Saving Features	Disable power saving feature in SB. As general rule, this feature should be disabled for desktop and enabled for mobile. See AMD SB700 Power Saving document for more details.
4892	Power Saving Features	Enable power saving feature in SB. As general rule, this feature should be disabled for desktop and enabled for mobile. See AMD SB700 Power Saving document for more details.
4893	USB PORT 1(BMC)	Disable USB port 1.
4894	USB PORT 1(BMC)	Enable USB port 1.
4895	USB PORT 5(Rear down)	Disable USB port 5.
4896	USB PORT 5(Rear down)	Enable USB port 5.
4897	USB PORT 6(Rear UP)	Disable USB port 6.
4898	USB PORT 6(Rear UP)	Enable USB port 6.
4899	USB PORT 10(Internal)	Disable USB port 10.
48A0	Non Coherent HT Link Speed	Set HT Link speed 800MHz.
48A1	Non Coherent HT Link Speed	Set HT Link speed 1000MHz.
48A2	Non Coherent HT Link Speed	Set HT Link speed 1200MHz.
48A3	Non Coherent HT Link Speed	Set HT Link speed 1600MHz.
48A4	Non Coherent HT Link Speed	Set HT Link speed 2000MHz.

Token	Setup option	Description
48A5	Non Coherent HT Link Speed	Set HT Link speed 2600MHz.
48A6	Non Coherent HT Link Width	Set HT Link 8 bit width.
48A7	Non Coherent HT Link Width	Set HT Link 16 bit width.
48B0	Event logging	Disable BIOS to record SR56x0 & MC4 Event Log.
48B1	Event logging	Enable BIOS to record SR56x0 & MC4 Event Log.
48B2	NMI on Error	Disable BIOS to generate NMI when uncorrectable error occurs.
48B3	NMI on Error	Enable BIOS to generate NMI when uncorrectable error occurs.
48B4	Power Management	Set PowerManagement to MaxPerformance Mode.
48B5	Power Management	Set PowerManagement to OS control Mode.
48B6	Power Management	Set PowerManagement to APML Mode.
48B7	IOMMU	Disabled IOMMU.
48B8	IOMMU	Enabled IOMMU.
48B9	DRAM Prefetcher	Prevents DRAM references from triggering DRAM prefetch requests.
48BA	DRAM Prefetcher	Turns on the DRAM prefetch unit in the Northbridge.
48BB	Hardware Prefetcher	Disabled Hardware Prefetcher.
48BC	Hardware Prefetcher	Enabled Hardware Prefetcher.
48BD	HW Prefetch Training on SW	Prevents hardware prefetcher from considering software prefetches when detecting strides for prefetch.
48BE	HW Prefetch Training on SW	Hardware prefetcher considers software prefetches when detecting strides for prefetch requests.

Token	Setup option	Description
4900	USB PORT 10(Internal)	Enable USB port 10.
48BF	Memory Remap(3GB-4GB)	Disable remap system memory space 3GB-4GB.
48C0	Memory Remap(3GB-4GB)	Enable remap system memory space 3GB-4GB.
48C1	OnChip SATA Type	Onboard SATA controller(s) is set to MS_AHCI mode.
48C2	DRAM Timing Config	Auto to configure DRAM Timing.
48C3	DRAM Timing Config	Manual to configure DRAM Timing.
48C4	Memory Clock Speed	Configure DRAM clock in 800MHz.
48C5	Memory Clock Speed	Configure DRAM clock in 1066MHz.
48C6	Memory Clock Speed	Configure DRAM clock in 1333MHz.
5001	PCI-E Slot ASPM	Controls the level of ASPM supported on the PCI Express Link of port 2. All entry disabled.
5002	PCI-E Slot ASPM	Controls the level of ASPM supported on the given PCI Express Link of port 2. L0s entry enabled.
5003	PCI-E Slot ASPM	Controls the level of ASPM supported on the given PCI Express Link of port 2. L1 entry enabled.
5004	PCI-E Slot ASPM	Controls the level of ASPM supported on the given PCI Express Link of port 2. L0s and L1 entry enabled.
5005	PCI-E Slot ASPM	Controls the level of ASPM supported on the given PCI Express Link of port 2. L0s entry downstream enabled.
5006	PCI-E Slot ASPM	Controls the level of ASPM supported on the given PCI Express Link of port 2. L0s entry downstream and L1 enabled.

Token	Setup option	Description
5021	Onboard Lan ASPM	Controls the level of ASPM supported on the PCI Express Link of port 4. All entry disabled.
5022	Onboard Lan ASPM	Controls the level of ASPM supported on the given PCI Express Link of port 4. L0s entry enabled.
5023	Onboard Lan ASPM	Controls the level of ASPM supported on the given PCI Express Link of port 4. L1 entry enabled.
5024	Onboard Lan ASPM	Controls the level of ASPM supported on the given PCI Express Link of port 4. L0s and L1 entry enabled.
5025	Onboard Lan ASPM	Controls the level of ASPM supported on the given PCI Express Link of port 4. L0s entry downstream enabled.
5026	Onboard Lan ASPM	Controls the level of ASPM supported on the given PCI Express Link of port 4. L0s entry downstream and L1 enabled.
5091	Mezzing Slot ASPM	Controls the level of ASPM supported on the PCI Express Link of port 11. All entry disabled.
5092	Mezzing Slot ASPM	Controls the level of ASPM supported on the given PCI Express Link of port 11. L0s entry enabled.
5093	Mezzing Slot ASPM	Controls the level of ASPM supported on the given PCI Express Link of port 11. L1 entry enabled.
5094	Mezzing Slot ASPM	Controls the level of ASPM supported on the given PCI Express Link of port 11. L0s and L1 entry enabled.
5095	Mezzing Slot ASPM	Controls the level of ASPM supported on the given PCI Express Link of port 11. L0s entry downstream enabled.
5096	Mezzing Slot ASPM	Controls the level of ASPM supported on the given PCI Express Link of port 11. L0s entry downstream and L1 enabled.
5121	Prob filter Mode	Set Probe filter mode to Auto.
5122	Prob filter Mode	Set Probe filter mode to disable.

Token	Setup option	Description
5123	VT-UTF8 Combo Key Support	Disable VT-UTF8 Combination Key Support for ANSI/VT100 terminals.
5124	VT-UTF8 Combo Key Support	Enable VT-UTF8 Combination Key Support for ANSI/VT100 terminals
5125	CS Sparing Enable	Not reserve a spare memory rank in each channel.
5126	CS Sparing Enable	Reserve a spare memory rank in each channel.

The IPMI command table

IPMI command	Setup option	Description
ipmitool raw 0x34 0x78 1 <LSB watt> <MSB watt>	PSU Power Capping	The setting controls PSU Power, its range limited in 150~2000W. The value will send to BMC by IPMI command and BMC will control PSU power. This setting only can be seen when “Power Management” be selected to “APML” mode and the system board at location 4 in the chassis.
ipmitool raw 0xc 1 1 3 <IP Address>	IP Address	Uses this option to input BMC LAN port IP address.
ipmitool raw 0xc 1 1 6 <Subnet Mask>	Subnet Mask	Uses this option to input BMC LAN port subnet mask address.
ipmitool raw 0xc 1 1 12 <IP Address>	GateWay Address	Uses this option to input BMC LAN port Gateway address.

IPMI command	Setup option	Description
<p>ipmitool raw 0x30 1 Return: ID</p> <p>ipmitool raw 0x30 3 ID 0x11 0x2 0 0 0 1 <Delay Mode></p>	<p>Power Staggering AC Recovery</p>	<p>Configures power recovery behavior. This item only can be seen when “Remote on AC Power Loss” be selected in “Power On” or “Last State”.</p> <p>This parameter is only effective if the Power Policy is not set to always off.</p> <p>0x00: Immediate Power On (No Delay) : Default</p> <p>0x01: Auto (Random), the auto generated delay time must be in the range of Minimum Power On Delay and Maximum Power On Delay.</p> <p>0x02: User Defined, the user defined delay time must be in the range of Minimum Power On Delay and Maximum Power On Delay.</p>
<p>ipmitool raw 0x30 1 Return: ID</p> <p>ipmitool raw 0x30 3 ID 0x11 0x4 0 0 0 1 <LSB timer> <MSB timer></p>	<p>Minimum Power On Delay</p>	<p>Configures time for power on delay, the setting range of delay time is 0~255sec.</p>
<p>ipmitool raw 0x30 1 Return: ID</p> <p>ipmitool raw 0x30 3 ID 0x11 0x5 0 0 0 1 <LSB timer> <MSB timer></p>	<p>Maximum Power On Delay</p>	<p>Configures time for power on delay, the setting range of delay time is 0~255sec.</p>
<p>ipmitool raw 0x30 1 Return: ID</p> <p>ipmitool raw 0x30 3 ID 0x11 0x3 0 0 0 1 <LSB timer> <MSB timer></p>	<p>Power On Delay</p>	<p>Configures time for power on delay, the setting range of delay time is 0~255sec.</p>

IPMI command	Setup option	Description
ipmitool raw 0x0a 0x42 Return: ID1 ID2	Clear BMC System Event Log	Clears all events in the BMC Event Log.
ipmitool raw 0x0a 0x47 ID1 ID2 0x43 0x4C 0x52 0xAA		

The Power Management Settings

SETUP Menu		Performance Settings		Power Optimized Settings	
		Option	D4 Token	Option	D4 Token
CPU Configuration	L3 Power Control	Enabled	4888	Disabled	4887
	DRAM Prefetcher	Enabled	48BA	Disabled	48B9
	Hardware Prefetcher	Enabled	48BC	Disabled	48BB
	HW Prefetch Training on SW	Enabled	48BE	Disabled	48BD
CPU Configuration ->Power Management	Power Management	Max. Performance	48B4	OS Control P-State 4	48B5 4864
SATA Configuration	Power Saving Features	Disabled	4891	Enabled	4892
	SATA-AHCI Ports Auto Clk Ctrl	Disabled	4871	Enabled	4872
	SATA-IDE Ports Auto Clk Ctrl	Disabled	4873	Enabled	4874

SETUP Menu		Performance Settings		Power Optimized Settings	
		Option	D4 Token	Option	D4 Token
Hyper Transport Configuration	Coherent HT Link Speed	HT3	4878	HT1	4877
	Non-Coherent HT Link Speed	HT3 2600MHz	48A5	HT1 800 (4 core processor) HT3 1200 (6 core processor)	48A0 48A2
	Non-Coherent HT Link Width	16 bits	48A7	8 bit	48A6
PCI Configuration -> Active State Power Management Configuration	PCI-E Slot ASPM	Disabled	5001	L0s & L1	5004
	Onboard LAN ASPM	Disabled	5021	L0s & L1	5024
	Mezzing Slot ASPM	Disabled	5091	L0s & L1	5094
	NB-SB Link ASPM	Disabled	4883	L1	4884

Installing System Components

Safety Instructions



WARNING: Working on systems that are still connected to a power supply can be extremely dangerous.



CAUTION: System components and electronic circuit boards can be damaged by discharge of static electricity.



CAUTION: Many repairs may only be done by a certified service technician. You should only perform troubleshooting and simple repairs as authorized in your product documentation, or as directed by the online or telephone service and support team. Damage due to servicing that is not authorized by Dell is not covered by your warranty. Read and follow the safety instructions that came with the product.

To avoid injury to yourself or damage to system, follow these guidelines:

- Always disconnect the system from the power outlet whenever you are working inside the system.
- If possible, wear a grounded wrist strap as you work inside the system. Or discharge any static electricity by touching the bare metal chassis of system case, or the bare metal body of any other grounded appliance.
- Hold electronic circuit boards by the edges only. Do not touch the components on the board unless it is necessary to do so. Do not flex or stress the circuit board.
- Leave all components inside the static-proof packaging until you are ready to use the component for the installation.

Recommended Tools

- #1 Phillips screwdriver
- #2 Phillips screwdriver

Inside the System



CAUTION: Many repairs may only be done by a certified service technician. You should only perform troubleshooting and simple repairs as authorized in your product documentation, or as directed by the online or telephone service and support team. Damage due to servicing that is not authorized by Dell is not covered by your warranty. Read and follow the safety instructions that came with the product.



CAUTION: This system must be operated with the system cover installed to ensure proper cooling.



NOTE: The illustration in this section shows a system with 3.5-inch hard drives.

Figure 3-1. Inside the System

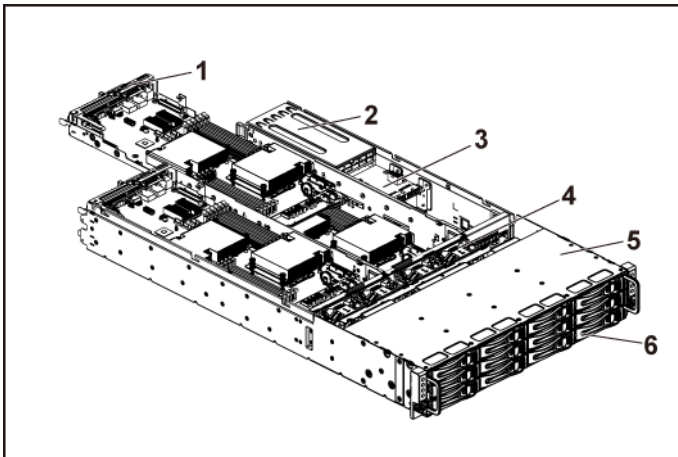

- | | | | |
|---|------------------------------|---|------------------|
| 1 | system board assembly (4) | 2 | power supply (2) |
| 3 | power distribution board (2) | 4 | cooling fan (4) |
| 5 | hard-drive bay | 6 | hard drive (12) |

Hard Drives

The installation and removal procedures for the 3.5-inch hard drive and the 2.5-inch hard drive are similar. Following is an example showing the replacement procedure of a 3.5-inch hard drive.

Removing a Hard-Drive Blank



CAUTION: To maintain proper system cooling, all empty hard-drive bays must have drive blanks installed.



NOTE: This section is applicable to systems with hot-swappable hard drives only.

- 1 Turn the lock lever counterclockwise until it points to the unlock symbol.
- 2 Slide the release button to open the release handle. See Figure 3-2.
- 3 Using the release handle, pull the hard-drive blank out of the hard-drive bay.

Figure 3-2. Removing or Installing a Hard-Drive Blank

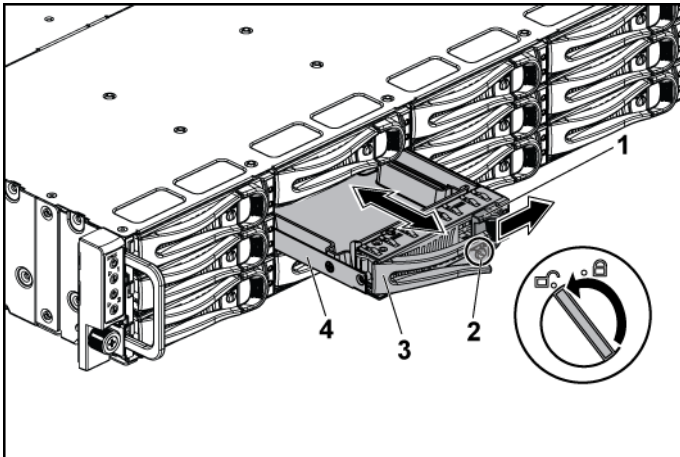

- | | | | |
|---|----------------|---|------------------|
| 1 | release button | 2 | lock lever |
| 3 | release handle | 4 | hard-drive blank |

Installing a Hard-Drive Blank

- 1 With the lever on the hard-drive blank open, slide the hard-drive blank into the drive bay until the hard-drive blank makes contact with the backplane. See Figure 3-2.
- 2 Close the release handle to lock the hard drive blank in place.
- 3 Turn the lock lever clockwise to the lock symbol. See Figure 3-2.

Removing a Hard-Drive Carrier



CAUTION: Many repairs may only be done by a certified service technician. You should only perform troubleshooting and simple repairs as authorized in your product documentation, or as directed by the online or telephone service and support team. Damage due to servicing that is not authorized by Dell is not covered by your warranty. Read and follow the safety instructions that came with the product.



CAUTION: To maintain proper system cooling, all empty hard-drive bays must have drive blanks installed.

- 1 Turn the lock lever counterclockwise until it points to the unlock symbol.
- 2 Slide the release button to open the release handle. See Figure 3-3.
- 3 Using the release handle, pull the hard-drive carrier out of the hard-drive bay.

Figure 3-3. Removing and Installing a Hard-Drive Carrier

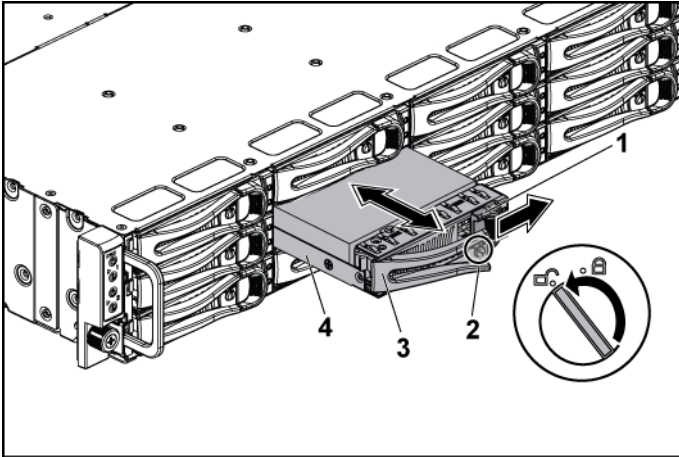

- | | | | |
|---|----------------|---|--------------------|
| 1 | release button | 2 | lock lever |
| 3 | release handle | 4 | hard-drive carrier |

Installing a Hard-Drive Carrier

CAUTION: Many repairs may only be done by a certified service technician. You should only perform troubleshooting and simple repairs as authorized in your product documentation, or as directed by the online or telephone service and support team. Damage due to servicing that is not authorized by Dell is not covered by your warranty. Read and follow the safety instructions that came with the product.

CAUTION: To maintain proper system cooling, all empty hard-drive bays must have drive blanks installed.

- 1 With the lever on the hard-drive carrier open, slide the hard-drive carrier into the drive bay until the hard-drive carrier makes contact with the backplane. See Figure 3-3.
- 2 Close the release handle to lock the hard drive in place.
- 3 Turn the lock lever clockwise to the lock symbol. See Figure 3-3.

Removing a Hard Drive From a Hard-Drive Carrier





-  **CAUTION:** Many repairs may only be done by a certified service technician. You should only perform troubleshooting and simple repairs as authorized in your product documentation, or as directed by the online or telephone service and support team. Damage due to servicing that is not authorized by Dell is not covered by your warranty. Read and follow the safety instructions that came with the product.
 -  **CAUTION:** Combining SATA and SAS hard drives in the same system configuration is not supported.
 -  **CAUTION:** Use only hard drives that have been tested and approved for use with the SAS/SATA backplane.
 -  **CAUTION:** When installing a hard-drive carrier, ensure that the adjacent drives are fully installed. Inserting a hard-drive carrier and attempting to lock its handle next to a partially installed carrier can damage the partially installed carrier's shield spring and make it unusable.
 -  **CAUTION:** To prevent data loss, ensure that your operating system supports hot-swappable drive installation. See the documentation supplied with the operating system.
- 1 Remove the four screws. See Figure 3-4.
 - 2 Lift the hard drive out of the hard-drive carrier.

Figure 3-4. Removing and Installing a Hard Drive from the Hard-Drive Carrier



- | | | | |
|---|--------------------|---|-----------|
| 1 | hard drive | 2 | screw (4) |
| 3 | hard-drive carrier | | |

Installing a Hard Drive into a Hard-Drive Carrier

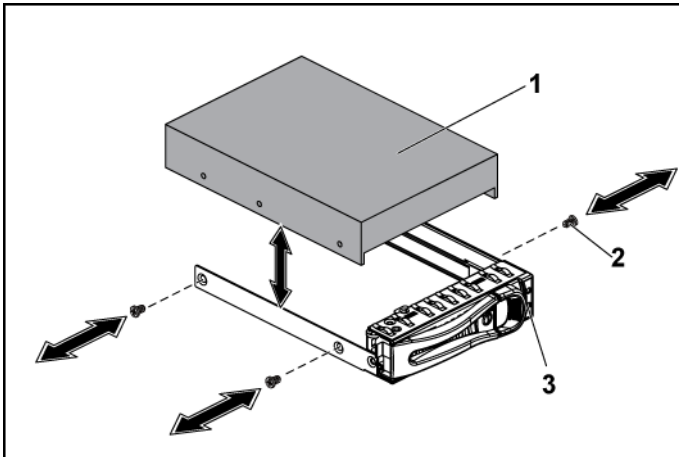

CAUTION: Many repairs may only be done by a certified service technician. You should only perform troubleshooting and simple repairs as authorized in your product documentation, or as directed by the online or telephone service and support team. Damage due to servicing that is not authorized by Dell is not covered by your warranty. Read and follow the safety instructions that came with the product.

- 1 Place the hard drive into the hard-drive carrier. See Figure 3-4.
- 2 Secure the hard drive to the hard-drive carrier with four screws. See Figure 3-4.

Power Supplies



NOTE: The following table lists the maximum supported configuration where power supply redundancy is guaranteed.



NOTE: Configurations higher than indicated in the table may change the power supply mode to non-redundant. In non-redundant mode if the power requirement exceeds the installed system power capacity, the BIOS will throttle the CPUs. Also, if CPU Power Capping is enabled, then CPU throttling occurs on configurations that exceed the cap value.

Table 3-1. PSU and System Board Support Matrix

PSU	Two System Boards	Four System Boards
1400W	Full configuration*	Up to two 95W processors / MLB, two hard drives / MLB, and four memory modules / MLB
1100W	Full configuration*	Up to two 65W processors / MLB, one hard drives / MLB, and six memory modules / MLB
750W	Up to two 95W processors / MLB, two hard drives / MLB, and four memory modules / MLB	N/A
470W	Up to two 35W processors / MLB, up to one hard drives / MLB, and three memory modules / MLB	N/A

Recommended Configuration

Memory - 4G, 1333, 2Rx4X72, 8, 240

HDD - 600G, SAS6, 15K, 3.5, SGT

Full Configuration

This includes full quantity of processors (95W), memory (4G, 1333, 2R) and HDD (600G, SAS6, 15K, 3.5).

Removing a Power Supply



CAUTION: Many repairs may only be done by a certified service technician. You should only perform troubleshooting and simple repairs as authorized in your product documentation, or as directed by the online or telephone service and support team. Damage due to servicing that is not authorized by Dell is not covered by your warranty. Read and follow the safety instructions that came with the product.



CAUTION: The System requires at least one power supply to operate normally.

- 1 Recommended to turn off the system, including any attached peripherals, and disconnect the system from the electrical outlet.
- 2 Disconnect the power cable from the power source and the power supply.
- 3 Press the release lever and using the handle, slide the power supply out of the system. See Figure 3-5.



NOTE: Removing the power supply may require considerable force.

Figure 3-5. Removing and Installing a Power Supply

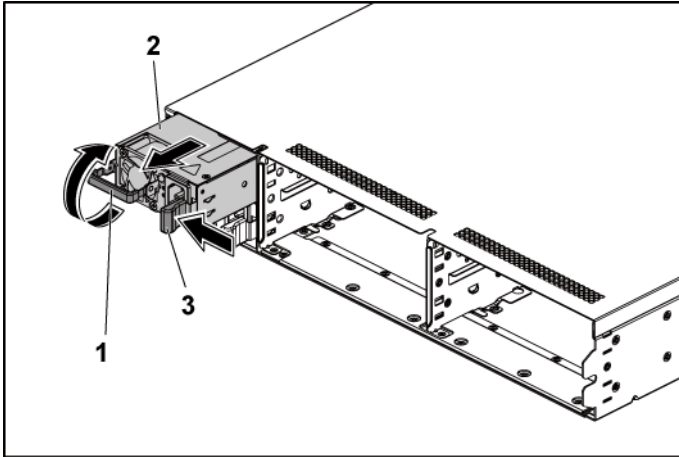

- | | | | |
|---|---------------|---|--------------|
| 1 | handle | 2 | power supply |
| 3 | release lever | | |

Installing a Power Supply

△ **CAUTION:** Many repairs may only be done by a certified service technician. You should only perform troubleshooting and simple repairs as authorized in your product documentation, or as directed by the online or telephone service and support team. Damage due to servicing that is not authorized by Dell is not covered by your warranty. Read and follow the safety instructions that came with the product.

△ **CAUTION:** The System requires at least one power supply to operate normally.

- 1 Verify that both power supplies are of the same type and have the same maximum output power.



NOTE: The maximum output power is printed on the power supply label.

- 2 Slide the new power supply into the chassis until the power supply is fully seated and the release lever snaps into place. See Figure 3-5.
- 3 Connect the power cable to the power supply and plug the cable into a power outlet.



NOTE: When installing a new power supply in a system with two power supplies, allow several seconds for the system to recognize the power supply and determine its status.

System-Board Assembly

Removing a System-Board Assembly



CAUTION: Many repairs may only be done by a certified service technician. You should only perform troubleshooting and simple repairs as authorized in your product documentation, or as directed by the online or telephone service and support team. Damage due to servicing that is not authorized by Dell is not covered by your warranty. Read and follow the safety instructions that came with the product.

- 1 Recommend to turn off the system board by pressing the power button on the back panel, and any attached peripherals.
- 2 Disconnect all the external cables from the system board.
- 3 Remove the screw that secures the retaining latch. See Figure 3-6.
- 4 Press the retaining latch and using the handle, slide the system-board assembly out of the chassis. See Figure 3-6.

Figure 3-6. Removing and Installing a System-Board Assembly

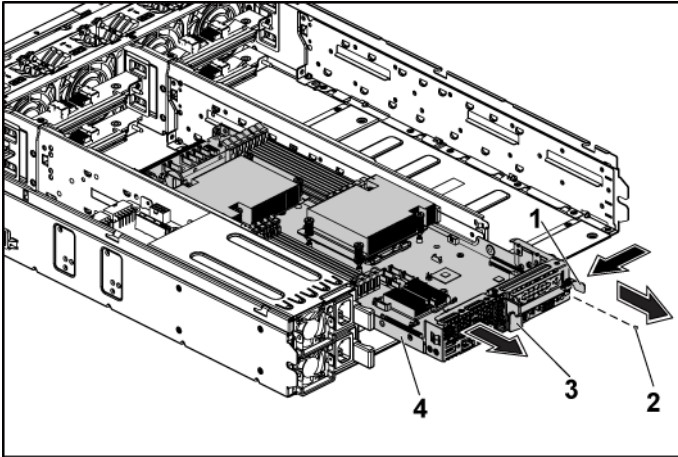

- | | | | |
|---|-----------------|---|-----------------------|
| 1 | retaining latch | 2 | screw |
| 3 | handle | 4 | system-board assembly |

Installing a System-Board Assembly



CAUTION: Many repairs may only be done by a certified service technician. You should only perform troubleshooting and simple repairs as authorized in your product documentation, or as directed by the online or telephone service and support team. Damage due to servicing that is not authorized by Dell is not covered by your warranty. Read and follow the safety instructions that came with the product.

- 1 Slide the system-board assembly into the chassis until it snaps into place. See Figure 3-6.
- 2 Reconnect all the external cables to the system board.
- 3 Replace the screw that secures the retaining latch. See Figure 3-6.
- 4 Turn on the system board by pressing the power button on the back panel, and the attached peripherals.

Heat Sinks

Removing the Heat Sink



CAUTION: Many repairs may only be done by a certified service technician. You should only perform troubleshooting and simple repairs as authorized in your product documentation, or as directed by the online or telephone service and support team. Damage due to servicing that is not authorized by Dell is not covered by your warranty. Read and follow the safety instructions that came with the product.

- 1 Remove the system-board assembly. See “Removing a System-Board Assembly” on page 92.



WARNING: The heat sink may be hot to touch for some time after the system has been powered down. Allow the heat sink to cool before removing it.



CAUTION: Never remove the heat sink from a processor unless you intend to remove the processor. The heat sink is necessary to maintain proper thermal conditions.

- 2 Using a Phillips screwdriver, loosen one of the heat-sink retention screws. See Figure 3-7.
Wait for 30 seconds for the heat sink to loosen from the processor.
- 3 Remove the other three heat-sink retention screws.
- 4 Gently lift the heat sink off the processor and set the heat sink aside with thermal grease side facing up.

Figure 3-7. Removing and Installing the Heat Sink

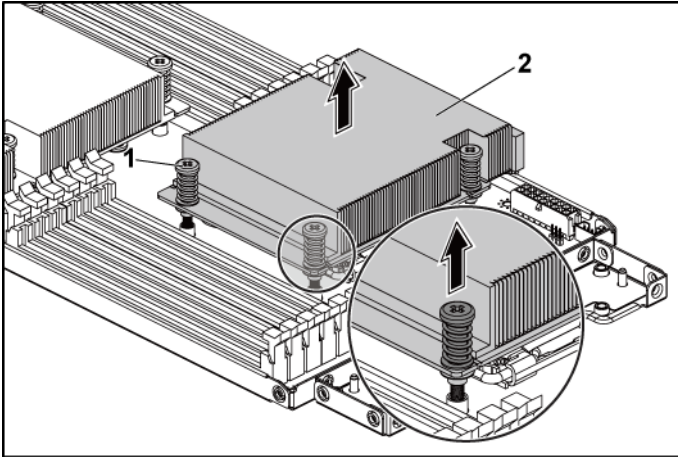

1 screw (4)

2 heat sink

Installing the Heat Sink



CAUTION: Many repairs may only be done by a certified service technician. You should only perform troubleshooting and simple repairs as authorized in your product documentation, or as directed by the online or telephone service and support team. Damage due to servicing that is not authorized by Dell is not covered by your warranty. Read and follow the safety instructions that came with the product.

- 1 Using a clean lint-free cloth, remove the thermal grease from the heat sink.
- 2 Apply new thermal grease evenly to the center of the top of the new processor.



CAUTION: Using excess thermal grease can cause grease to contact the processor shield, which can cause contamination of the processor socket.

- 3 Place the heat sink on the processor. See Figure 3-7.

- 4 Using a Phillips screwdriver, tighten the four heat-sink retention screws.
- 5 Replace the system-board assembly. See "Installing a System-Board Assembly" on page 93.

Processors

Removing a Processor

 **CAUTION: Many repairs may only be done by a certified service technician. You should only perform troubleshooting and simple repairs as authorized in your product documentation, or as directed by the online or telephone service and support team. Damage due to servicing that is not authorized by Dell is not covered by your warranty. Read and follow the safety instructions that came with the product.**

- 1 Remove the system-board assembly. See "Removing a System-Board Assembly" on page 92.
- 2 Remove the heat sink, see "Removing the Heat Sink" on page 94.

 **CAUTION: The processor is held in its socket under strong pressure. Be aware that the release lever can spring up suddenly if not firmly grasped.**

- 3 Position your thumb firmly over the processor socket-release lever and release the lever from the locked position. Rotate the lever 90 degrees upward until the processor is released from the socket. See Figure 3-8.
- 4 Rotate the processor shield upward and out of the way. See Figure 3-8.
- 5 Lift the processor out of the socket and leave the socket-release lever up so that the socket is ready for the new processor.

 **CAUTION: Be careful not to bend any of the pins on the ZIF socket when removing the processor. Bending the pins can permanently damage the system board. Be sure to properly align the process or notch to the socket and insert straight down. Do not move from side to side.**

Figure 3-8. Removing and Installing a Processor



- | | | | |
|---|------------------------|---|----------------|
| 1 | processor shield | 2 | processor |
| 3 | notch in processor (2) | 4 | socket key (2) |
| 5 | socket-release lever | 6 | ZIF socket |

Installing a Processor

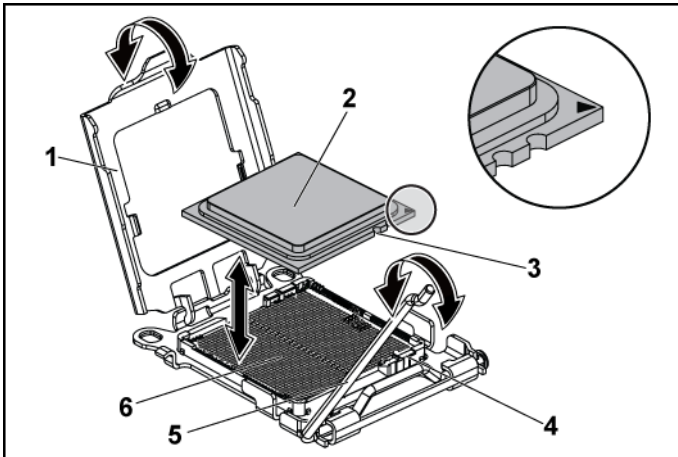

CAUTION: Many repairs may only be done by a certified service technician. You should only perform troubleshooting and simple repairs as authorized in your product documentation, or as directed by the online or telephone service and support team. Damage due to servicing that is not authorized by Dell is not covered by your warranty. Read and follow the safety instructions that came with the product.



NOTE: When installing only one processor, the processor must be installed in the processor0 (for the socket location, see “System Board Connectors” on page 198).



NOTE: If you are upgrading your processors, prior to upgrading your system, download and install the latest system BIOS version from support.dell.com. Follow the instructions included in the file download to install the update on your system.

- 1 Unpack the processor if it has not been used previously.
If the processor has already been used, remove any thermal grease from the top of the processor using a lint-free cloth.
- 2 Align the processor with the socket keys on the ZIF socket. See Figure 3-8.

 **CAUTION: Positioning the processor incorrectly can permanently damage the system board or the processor. Be careful not to bend the pins in the ZIF socket.**

- 3 With the release lever on the processor socket in the open position, align the processor with the socket keys and set the processor lightly in the socket. See Figure 3-8.

 **CAUTION: Do not use force to seat the processor. When the processor is positioned correctly, it engages easily into the socket.**

- 4 Close the processor shield.
- 5 Rotate the socket release lever down until it snaps into place.
- 6 Using a clean lint-free cloth, remove the thermal grease from the heat sink.
- 7 Apply thermal grease evenly to the center of the top of the new processor.

 **CAUTION: Using excess thermal grease can cause grease to contact the processor shield, which can cause contamination of the processor socket.**

- 8 Place the heat sink on the processor. See Figure 3-7.
- 9 Using a Phillips screwdriver, tighten the heat-sink retention screws. See Figure 3-7.
- 10 Replace the system-board assembly. See "Installing a System-Board Assembly" on page 93.
- 11 Reconnect the system to its electrical outlet and turn on the system, including any attached peripherals.
- 12 Press <F2> to enter the System Setup program, and check that the processor information matches the new system configuration. See "System Setup Options at Boot" on page 38.

Expansion-Card Assembly and Expansion Card

Removing the Expansion Card



CAUTION: Many repairs may only be done by a certified service technician. You should only perform troubleshooting and simple repairs as authorized in your product documentation, or as directed by the online or telephone service and support team. Damage due to servicing that is not authorized by Dell is not covered by your warranty. Read and follow the safety instructions that came with the product.

- 1 Remove the system-board assembly. See "Removing a System-Board Assembly" on page 92.
- 2 Remove the four screws that secure the expansion-card assembly. See Figure 3-9.
- 3 Lift the expansion-card assembly out of the system-board assembly. See Figure 3-9.

Figure 3-9. Removing the Expansion-Card Assembly

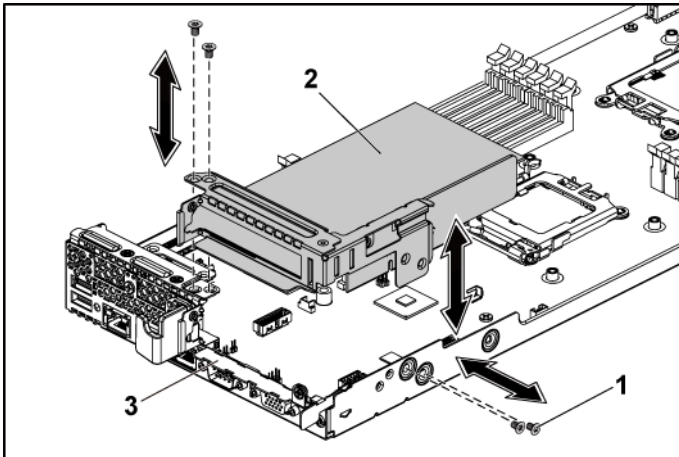

- | | | | |
|---|-----------------------|---|-------------------------|
| 1 | screw (4) | 2 | expansion-card assembly |
| 3 | system-board assembly | | |

- 4 Remove the screw securing the expansion card.
- 5 Grasp the expansion card by its edges, and carefully remove it from the expansion-card connector.
- 6 If you are removing the card permanently, install an expansion-card slot cover, and close the expansion-card latch.



NOTE: You must install a filler bracket over an empty expansion slot to maintain Federal Communications Commission (FCC) certification of the system. The brackets also keep dust and dirt out of the system and aid in proper cooling and airflow inside the system.

Figure 3-10. Removing the Expansion Card

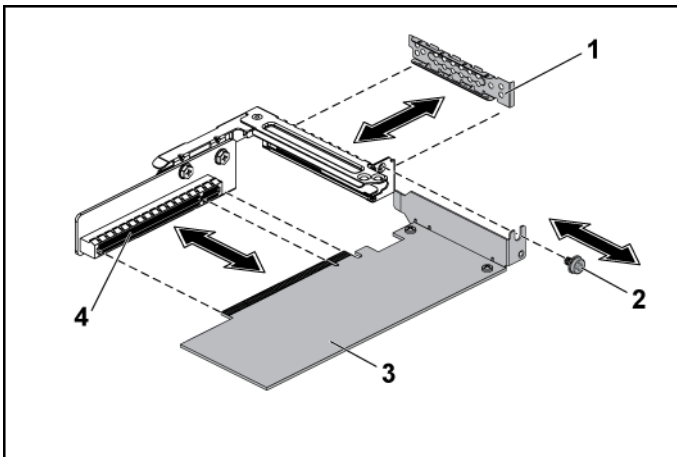

- | | | | |
|---|---------------------------|---|--------------------------|
| 1 | expansion-card slot cover | 2 | screw |
| 3 | expansion card | 4 | expansion-card connector |

Installing the Expansion Card



CAUTION: Many repairs may only be done by a certified service technician. You should only perform troubleshooting and simple repairs as authorized in your product documentation, or as directed by the online or telephone service and support team. Damage due to servicing that is not authorized by Dell is not covered by your warranty. Read and follow the safety instructions that came with the product.



CAUTION: Expansion cards can only be installed in the slots on the expansion-card riser. Do not attempt to install expansion cards directly into the riser connector on the system board.

- 1 Unpack the expansion card and prepare it for installation. For instructions, see the documentation accompanying the card.
- 2 Remove the system-board assembly. See "Removing a System-Board Assembly" on page 92.
- 3 Remove the four screws that secure the expansion-card assembly.
- 4 Lift the expansion-card assembly away from the system-board assembly.
- 5 Remove the screw securing the filler bracket.
- 6 Grasp the filler bracket by its edges, and carefully remove it from the expansion-card connector.



NOTE: Keep this bracket in case you need to remove the expansion card. Filler brackets must be installed over empty expansion-cards slots to maintain FCC certification of the system. The brackets also keep dust and dirt out of the system and aid in proper cooling and airflow inside the system.

- 7 Holding the card by its edges, position the card so that the card-edge connector aligns with the expansion-card connector on the expansion-card assembly.
- 8 Insert the card-edge connector firmly into the expansion-card connector until the card is fully seated.
- 9 Replace the screw securing the expansion card.

- 10 Place the expansion-card assembly into the system-board assembly.
- 11 Replace the four screws that secure the expansion-card assembly.
- 12 Replace the system-board assembly. See "Installing a System-Board Assembly" on page 93.

LSI 9260-8i Card



NOTE: The LSI 9260-8i card assembly should include the BBU interposer card which is connected to the RAID battery. The illustrations in this section are just for your removal and installation reference. For more information of the RAID battery, see "LSI 9260-8i RAID Battery (Optional)" on page 107.

Removing the LSI 9260-8i Card



CAUTION: Many repairs may only be done by a certified service technician. You should only perform troubleshooting and simple repairs as authorized in your product documentation, or as directed by the online or telephone service and support team. Damage due to servicing that is not authorized by Dell is not covered by your warranty. Read and follow the safety instructions that came with the product.

- 1 Remove the system-board assembly. See "Removing a System-Board Assembly" on page 92.
- 2 Disconnect the two SAS/SGPIO cables connecting to the LSI 9260-8i card assembly.
- 3 Remove the four screws that secure the LSI 9260-8i card assembly. See Figure 3-11.
- 4 Lift the LSI 9260-8i card assembly out of the system-board assembly. See Figure 3-11.

Figure 3-11. Removing the LSI 9260-8i Card Assembly

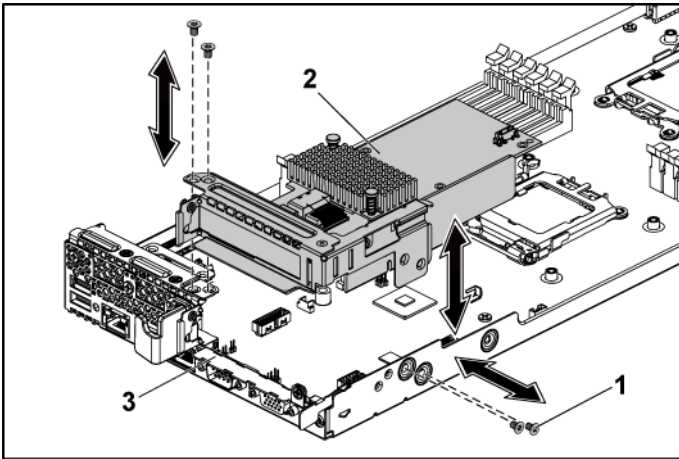

- 1 screw (4)
- 2 LSI 9260-8i-card assembly
- 3 system-board assembly

- 5 Remove the screw securing the LSI 9260-8i card.
- 6 Grasp the LSI 9260-8i card by its edges, and carefully remove it from the expansion-card connector.
- 7 If you are removing the card permanently, install an expansion-card slot cover over the empty expansion slot opening, and close the expansion-card latch.



NOTE: You must install a filler bracket over an empty expansion slot to maintain Federal Communications Commission (FCC) certification of the system. The brackets also keep dust and dirt out of the system and aid in proper cooling and airflow inside the system.

Figure 3-12. Removing the LSI 9260-8i Card

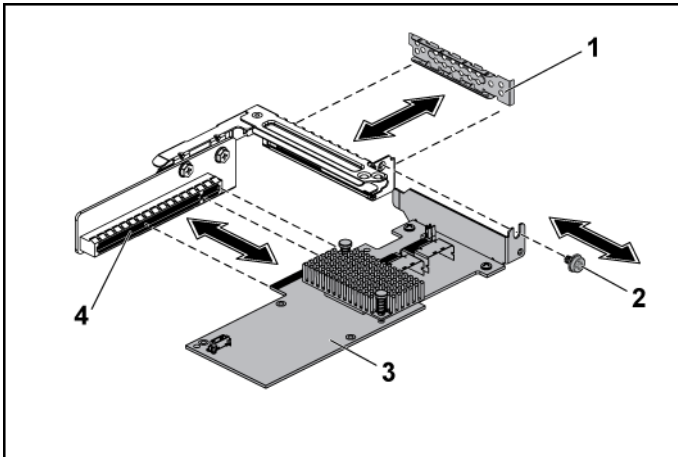

- | | | | |
|---|---------------------------|---|--------------------------|
| 1 | expansion-card slot cover | 2 | screw |
| 3 | LSI 9260-8i card | 4 | expansion-card connector |

- 8 Remove the BBU interposer card by unscrewing the three screws.
- 9 Lift the BBU interposer card away from the LSI9260-8i card.
- 10 Disconnect the RAID battery cable from the BBU interposer card.

Installing the LSI 9260-8i Card



CAUTION: Many repairs may only be done by a certified service technician. You should only perform troubleshooting and simple repairs as authorized in your product documentation, or as directed by the online or telephone service and support team. Damage due to servicing that is not authorized by Dell is not covered by your warranty. Read and follow the safety instructions that came with the product.



CAUTION: Expansion cards can only be installed in the slots on the expansion-card riser. Do not attempt to install expansion cards directly into the riser connector on the system board.

- 1 Unpack the LSI 9260-8i card and prepare it for installation. For instructions, see the documentation accompanying the card.
- 2 Remove the system-board assembly. See "Removing a System-Board Assembly" on page 92.
- 3 Connect the RAID battery cable to the BBU interposer card. See Figure 3-13.
- 4 Attach the BBU interposer card onto the LSI 9260-8i card by securing the three screws coming with the RAID battery. For the installation steps of the RAID battery, see "LSI 9260-8i RAID Battery (Optional)" on page 107.
- 5 Remove the screw securing the filler bracket. Grasp the filler bracket by its edges, and carefully remove it from the expansion-card connector. See Figure 3-12.



NOTE: Keep this bracket in case you need to remove the expansion card. Filler brackets must be installed over empty expansion-cards slots to maintain FCC certification of the system. The brackets also keep dust and dirt out of the system and aid in proper cooling and airflow inside the system.

- 6 Connect the two SAS/SGPIO cables to the LSI 9260-8i card assembly. See Figure 3-13.
- 7 Holding the card by its edges, position the card so that the card-edge connector aligns with the expansion-card connector. See Figure 3-12.
- 8 Insert the card-edge connector firmly into the expansion-card connector until the card is fully seated.
- 9 Replace the screw securing the LSI 9260-8i card.
- 10 Place the LSI 9260-8i card assembly into the system-board assembly. See Figure 3-11.
- 11 Replace the four screws that secure the LSI 9260-8i card assembly. Make sure the cable is routed properly as shown in Figure 3-13.
- 12 Install the system-board assembly. See "Installing a System-Board Assembly" on page 93.

Cable Routing for LSI 9260-8i Card

- 1 Connect the RAID battery cable to the BBU interposer card on the LSI 9260-8i card, and connect the other end of the cable to the connector on the RAID battery. See Figure 3-13 for the cable routing. See

- 2 **Figure 3-14. Removing and Installing the LSI 9260-8i RAID Battery**
- 3 for the RAID battery connector.
- 4 Connect the mini-SAS&SGPIO cable to the LSI 9260-8i card, and connect the other end of the cable to the corresponding connectors on the interposer extender. See Figure 3-13 for the cable routing. See Figure 5-9 for the interposer extender connectors.



NOTE: When connecting the RAID battery cable, the BBU interposer card should be installed on the LSI 9260-8i card. The BBU interposer card in the figure below is just for you reference.

Figure 3-13. Cable Routing for LSI 9260-8i Card

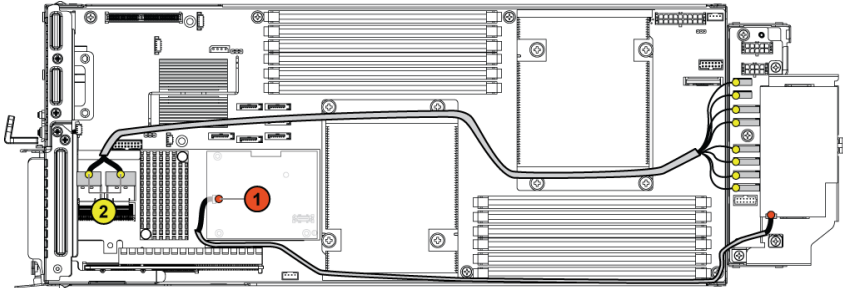

Item	Cable	From (LSI 9260-8i Card)	To (RAID Battery and HDD to Backplane SATAII Connectors)
①	RAID battery cable	RAID battery connector (J4)	RAID battery connector
②	SAS/SGPIO cable	Mini-SAS connector A & Mini-SAS connector B	SATAII connectors 0~5 and SGPIO A&B

LSI 9260-8i RAID Battery (Optional)

Removing the LSI 9260-8i RAID Battery



CAUTION: Many repairs may only be done by a certified service technician. You should only perform troubleshooting and simple repairs as authorized in your product documentation, or as directed by the online or telephone service and support team. Damage due to servicing that is not authorized by Dell is not covered by your warranty. Read and follow the safety instructions that came with the product.



NOTE: The information in this section applies only to systems with the optional RAID controller card.

- 1 Remove the system-board assembly. See “Removing a System-Board Assembly” on page 92.
- 2 Disconnect the cable connecting to the LSI 9260-8i RAID battery.
- 3 Press the LSI 9260-8i RAID battery latch and lift the LSI 9260-8i RAID battery to release it from the LSI 9260-8i RAID battery carrier. See Figure 3-14.
- 4 Slide and lift the LSI 9260-8i RAID battery away from the LSI 9260-8i RAID battery carrier. See Figure 3-14.

Figure 3-14. Removing and Installing the LSI 9260-8i RAID Battery

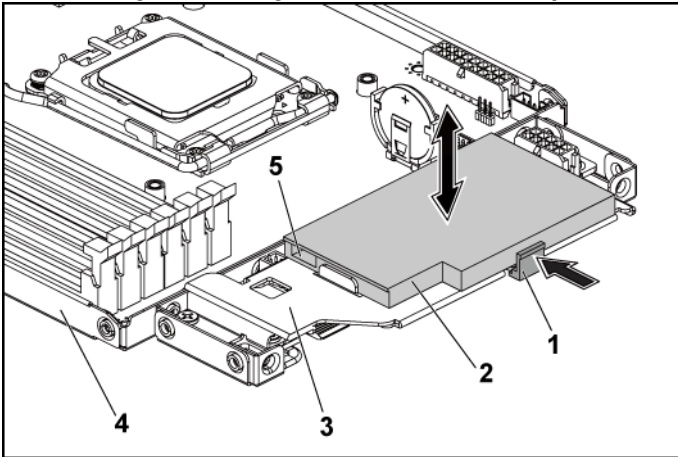

- | | | | |
|---|----------------------------------|---|--------------------------|
| 1 | RAID battery latch | 2 | LSI 9260-8i RAID battery |
| 3 | LSI 9260-8i RAID battery carrier | 4 | system-board assembly |
| 5 | RAID battery connector | | |

Installing the LSI 9260-8i RAID Battery

- 1 Insert the LSI 9260-8i RAID battery into the battery carrier until the RAID battery latch locks into place. See Figure 3-14.
- 2 Reconnect the cable connecting to the LSI 9260-8i RAID battery. Make sure the cable is routed properly as shown in Figure 3-13.
- 3 Replace the system-board assembly. See “Installing a System-Board Assembly” on page 93.

Removing the LSI 9260-8i RAID Battery Carrier



CAUTION: Many repairs may only be done by a certified service technician. You should only perform troubleshooting and simple repairs as authorized in your product documentation, or as directed by the online or telephone service and support team. Damage due to servicing that is not authorized by Dell is not covered by your warranty. Read and follow the safety instructions that came with the product.



NOTE: The information in this section applies only to systems with the optional RAID controller card.

- 1 Remove the system-board assembly. See “Removing a System-Board Assembly” on page 92.
- 2 Remove the LSI 9260-8i RAID battery. See “Removing the LSI 9260-8i RAID Battery” on page 107.
- 3 Remove the three screws securing the LSI 9260-8i RAID battery carrier to the interposer extender, and lift the LSI 9260-8i RAID battery carrier away from the interposer extender. See Figure 3-15 .

Figure 3-15. Removing and Installing the LSI 9260-8i RAID Battery Carrier

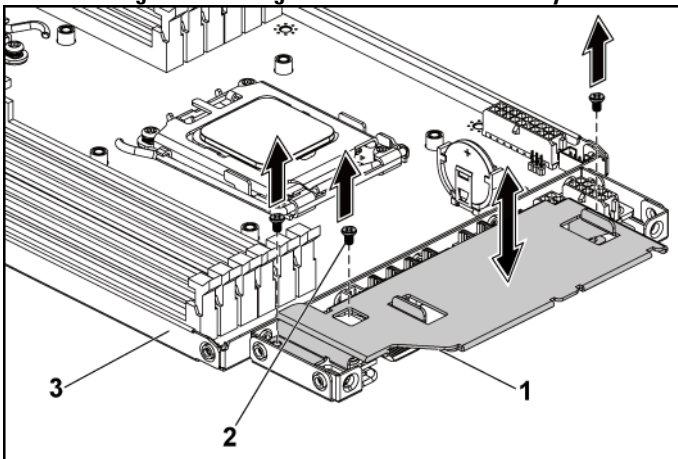

- | | | | |
|---|----------------------------------|---|-----------|
| 1 | LSI 9260-8i RAID battery carrier | 2 | screw (3) |
| 3 | system-board assembly | | |

Installing the LSI 9260-8i RAID Battery Carrier

- 1 Place the LSI 9260-8i RAID battery carrier in position on the interposer extender. See Figure 3-15.
- 2 Replace the screws securing the LSI 9260-8i RAID battery carrier to the interposer extender. See Figure 3-15.
- 3 Install the LSI 9260-8i RAID battery into the LSI 9260-8i RAID battery carrier. See “Installing the LSI 9260-8i RAID Battery” on page 108.
- 4 Replace the system-board assembly. See “Installing a System-Board Assembly” on page 93.

LSI 9265-8i Card



NOTE: The LSI 9265-8i card assembly should include the BBU interposer card which is connected to the RAID battery. The illustrations in this section are just for your removal and installation reference. For more information of the RAID battery, see “LSI 9265-8i RAID Battery (Optional)” on page 115.

Removing the LSI 9265-8i Card



CAUTION: Many repairs may only be done by a certified service technician. You should only perform troubleshooting and simple repairs as authorized in your product documentation, or as directed by the online or telephone service and support team. Damage due to servicing that is not authorized by Dell is not covered by your warranty. Read and follow the safety instructions that came with the product.

- 1 Remove the system-board assembly. See "Removing a System-Board Assembly" on page 92.
- 2 Disconnect the two SAS/SGPIO cables connecting to the LSI 9265-8i card assembly.
- 3 Remove the four screws that secure the LSI 9265-8i card assembly. See Figure 3-16.

- 4 Lift the LSI 9265-8i card assembly out of the system-board assembly.
See Figure 3-16.

Figure 3-16. Removing the LSI 9265-8i Card Assembly

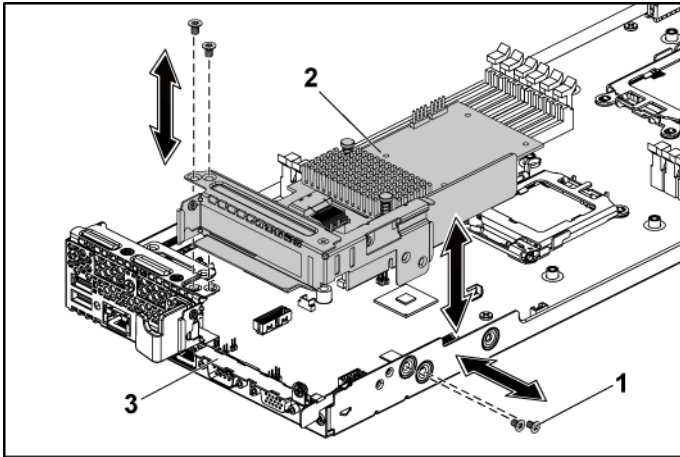

- | | | | |
|---|-----------------------|---|---------------------------|
| 1 | screw (4) | 2 | LSI 9265-8i-card assembly |
| 3 | system-board assembly | | |

- 5 Remove the screw securing the LSI 9265-8i card. See Figure 3-17.
- 6 Grasp the LSI 9265-8i card by its edges, and carefully remove it from the expansion-card connector. See Figure 3-17.
- 7 If you are removing the card permanently, install an expansion-card slot cover over the empty expansion slot opening, and close the expansion-card latch.



NOTE: You must install a filler bracket over an empty expansion slot to maintain Federal Communications Commission (FCC) certification of the system. The brackets also keep dust and dirt out of the system and aid in proper cooling and airflow inside the system.

Figure 3-17. Removing the LSI 9265-8i Card

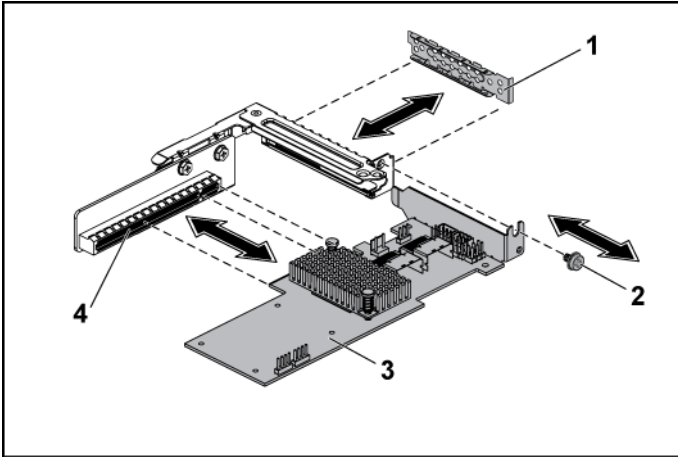

- | | | | |
|---|---------------------------|---|--------------------------|
| 1 | expansion-card slot cover | 2 | screw |
| 3 | LSI 9265-8i card | 4 | expansion-card connector |

- 8 Lift the BBU interposer card away from the LSI9265-8i card.
- 9 Disconnect the RAID battery cable from the BBU interposer card.

Installing the LSI 9265-8i Card



CAUTION: Many repairs may only be done by a certified service technician. You should only perform troubleshooting and simple repairs as authorized in your product documentation, or as directed by the online or telephone service and support team. Damage due to servicing that is not authorized by Dell is not covered by your warranty. Read and follow the safety instructions that came with the product.



CAUTION: Expansion cards can only be installed in the slots on the expansion-card riser. Do not attempt to install expansion cards directly into the riser connector on the system board.

1. Unpack the LSI 9265-8i card and prepare it for installation. For instructions, see the documentation accompanying the card.
2. Remove the system-board assembly. See "Removing a System-Board Assembly" on page 92.
3. Connect the RAID battery cable to the BBU interposer card. See Figure 3-18.
4. Install the BBU interposer card onto the LSI 9265-8i card.
5. Remove the screw securing the filler bracket. Grasp the filler bracket by its edges, and carefully remove it from the expansion-card connector. See Figure 3-17.



NOTE: Keep this bracket in case you need to remove the expansion card. Filler brackets must be installed over empty expansion-cards slots to maintain FCC certification of the system. The brackets also keep dust and dirt out of the system and aid in proper cooling and airflow inside the system.

6. Connect the two SAS/SGPIO cables to the LSI 9265-8i card assembly. See Figure 3-18.

- 7 Holding the card by its edges, position the card so that the card-edge connector aligns with the expansion-card connector. See Figure 3-17.
- 8 Insert the card-edge connector firmly into the expansion-card connector until the card is fully seated.
- 9 Replace the screw securing the LSI 9265-8i card.
- 10 Place the LSI 9265-8i card assembly into the system-board assembly. See Figure 3-16.
- 11 Replace the four screws that secure the LSI 9265-8i card assembly. Make sure the cable is routed properly as shown in Figure 3-18.
- 12 Install the system-board assembly. See "Installing a System-Board Assembly" on page 93.

Cable Routing for LSI 9265-8i Card

- 1 Connect the mini-SAS&SGPIO cable to the LSI 9265-8i card, and connect the other end of the cable to the corresponding connectors on the interposer extender. Make sure the cables should go through the cable clip ring. See Figure 3-18.
- 2 Connect the RAID battery cable to the BBU interposer card on the LSI 9265-8i card, and connect the other end of the cable to the corresponding connector on the RAID battery.



NOTE: When connecting the RAID battery cable, the BBU interposer card should be installed on the LSI 9265-8i card. The BBU interposer card in the figure below is just for you reference.

Figure 3-18. Cable Routing for LSI 9265-8i Card

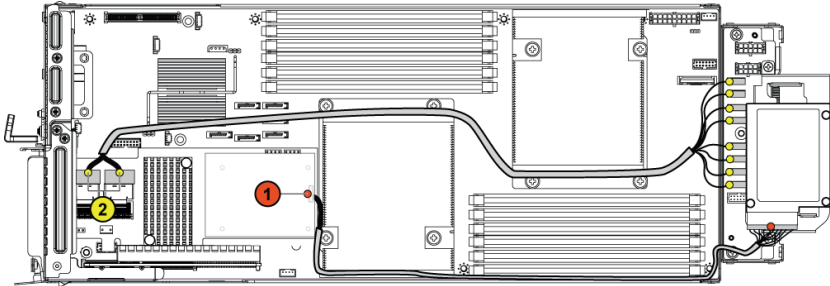

Item	Cable	From (LSI 9265-8i Card)	To (RAID Battery and HDD to Backplane SATAII Connectors)
1	RAID battery cable	RAID battery connector (J4)	RAID battery connector
2	SAS/SGPIO cable	Mini-SAS connector A & Mini-SAS connector B	SATAII connectors 0~5 and SGPIO A&B

LSI 9265-8i RAID Battery (Optional)

Removing the LSI 9265-8i RAID Battery Assembly



CAUTION: Many repairs may only be done by a certified service technician. You should only perform troubleshooting and simple repairs as authorized in your product documentation, or as directed by the online or telephone service and support team. Damage due to servicing that is not authorized by Dell is not covered by your warranty. Read and follow the safety instructions that came with the product.



NOTE: The information in this section applies only to systems intalled with the LSI 9265-8i card.

- 1 Remove the system-board assembly. See “Removing a System-Board Assembly” on page 92.
- 2 Disconnect the cable connecting to the LSI 9265-8i card.
- 3 Remove the screws that secure the RAID battery assembly to the interposer extender. See Figure 3-19.
- 4 Lift the LSI 9265-8i RAID battery assembly away from the interposer extender. See Figure 3-19.

Figure 3-19. Removing and Installing the LSI 9265-8i RAID Battery Assembly

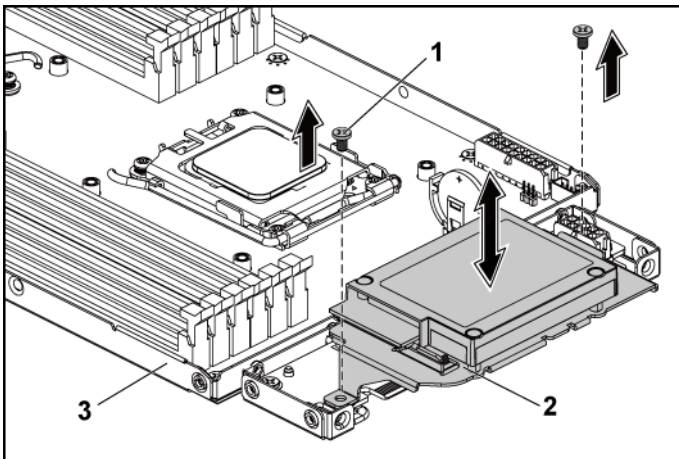

- | | | | |
|---|-----------------------|---|-----------------------------------|
| 1 | screws (2) | 2 | LSI 9265-8i RAID battery assembly |
| 3 | system-board assembly | | |

Installing the LSI 9265-8i RAID Battery Assembly

- 1 Place the LSI 9265-8i RAID battery assembly in position on the interposer extender. See Figure 3-19.
- 2 Replace the screws securing the LSI 9265-8i RAID battery assembly to the interposer extender. See Figure 3-19.

- 3 Reconnect the cable connecting to the LSI 9265-8i card. Make sure the cable is routed properly as shown in Figure 3-18.
- 4 Install the system-board assembly. See “Installing a System-Board Assembly” on page 93.

Removing the LSI 9265-8i RAID Battery



CAUTION: Many repairs may only be done by a certified service technician. You should only perform troubleshooting and simple repairs as authorized in your product documentation, or as directed by the online or telephone service and support team. Damage due to servicing that is not authorized by Dell is not covered by your warranty. Read and follow the safety instructions that came with the product.



NOTE: The information in this section applies only to systems with the optional RAID controller card.

- 1 Remove the system-board assembly. See “Removing a System-Board Assembly” on page 92.
- 2 Disconnect the cable connecting to the LSI 9265-8i card.
- 3 Remove the LSI 9265-8i RAID battery assembly. See Figure 3-19.
- 4 Remove the screws that secure the LSI 9265-8i RAID battery to the LSI 9265-8i RAID battery carrier. See “Removing the LSI 9265-8i RAID Battery” on page 115.
- 5 Lift the LSI 9265-8i RAID battery away from the LSI 9265-8i RAID battery carrier. See Figure 3-20.

Figure 3-20. Removing and Installing the LSI 9265-8i RAID Battery

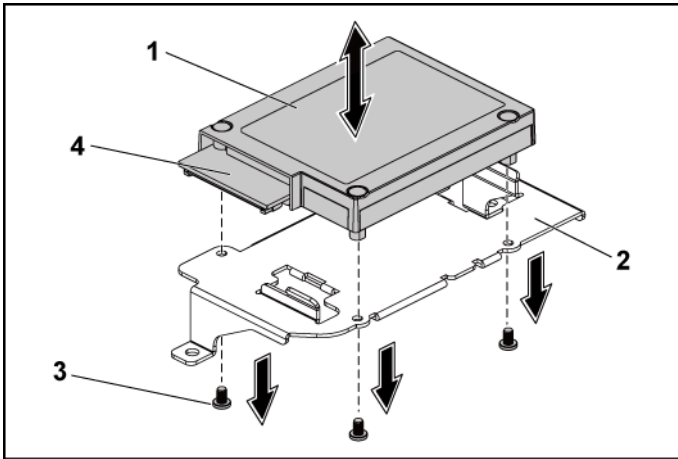

- | | | | |
|---|--------------------------|---|----------------------------------|
| 1 | LSI 9265-8i RAID battery | 2 | LSI 9265-8i RAID battery carrier |
| 3 | screw (3) | 4 | RAID battery connector |

Installing the LSI 9265-8i RAID Battery

- 1 Attach the LSI 9265-8i RAID battery onto the LSI 9265-8i RAID battery carrier. See Figure 3-20.
- 2 Replace the screws securing the LSI 9265-8i RAID battery to the LSI 9265-8i RAID battery carrier. See Figure 3-20.
- 3 Install the LSI 9265-8i RAID battery. See “Installing the LSI 9265-8i RAID Battery” on page 116.
- 4 Reconnect the cable connecting to the LSI 9265-8i card.
- 5 Install the system-board assembly. See “Installing a System-Board Assembly” on page 93.

Expansion-Card Connector

Removing the Expansion-Card Connector



CAUTION: Many repairs may only be done by a certified service technician. You should only perform troubleshooting and simple repairs as authorized in your product documentation, or as directed by the online or telephone service and support team. Damage due to servicing that is not authorized by Dell is not covered by your warranty. Read and follow the safety instructions that came with the product.

- 1 Remove the system-board assembly. See "Removing a System-Board Assembly" on page 92.
- 2 Remove the expansion card. See "Removing the Expansion Card" on page 99.
- 3 Remove the two screws securing the expansion-card connector to the expansion-card bracket. See Figure 3-21.
- 4 Pull the expansion-card connector away from the expansion-card racket. See Figure 3-21.

Figure 3-21. Removing and Installing the Expansion-Card Connector

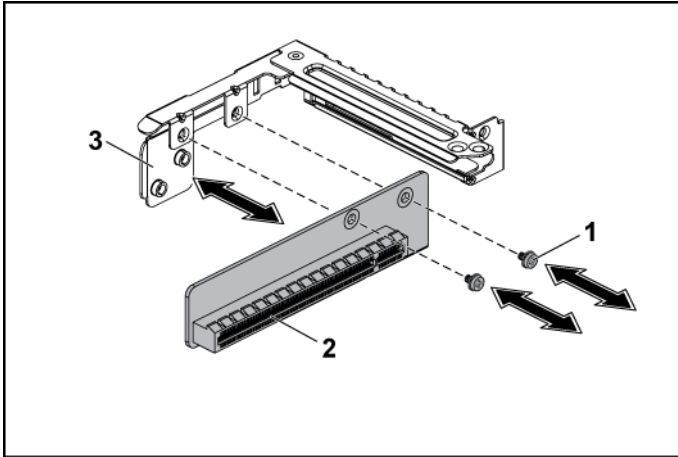

- 1 screw (2)
- 2 expansion-card connector
- 3 expansion-card bracket

Installing the Expansion-Card Connector



CAUTION: Many repairs may only be done by a certified service technician. You should only perform troubleshooting and simple repairs as authorized in your product documentation, or as directed by the online or telephone service and support team. Damage due to servicing that is not authorized by Dell is not covered by your warranty. Read and follow the safety instructions that came with the product.

- 1 Place the expansion-card connector into the expansion-card bracket. See Figure 3-21.
- 2 Replace the two screws securing the expansion-card connector to the expansion-card bracket. See Figure 3-21.

- 3 Install the expansion card. See "Installing the Expansion Card" on page 101.
- 4 Replace the system-board assembly. See "Installing a System-Board Assembly" on page 93.

Optional Daughter Cards

Removing the SAS Daughter Card



CAUTION: Many repairs may only be done by a certified service technician. You should only perform troubleshooting and simple repairs as authorized in your product documentation, or as directed by the online or telephone service and support team. Damage due to servicing that is not authorized by Dell is not covered by your warranty. Read and follow the safety instructions that came with the product.

- 1 Remove the system-board assembly. See "Removing a System-Board Assembly" on page 92.
- 2 Disconnect all the cables from the daughter card.
- 3 Remove the three screws that secure the daughter card. See Figure 3-22.
- 4 Lift the daughter card out of the system-board assembly. See Figure 3-22.

Figure 3-22. Removing and Installing the SAS Daughter Card

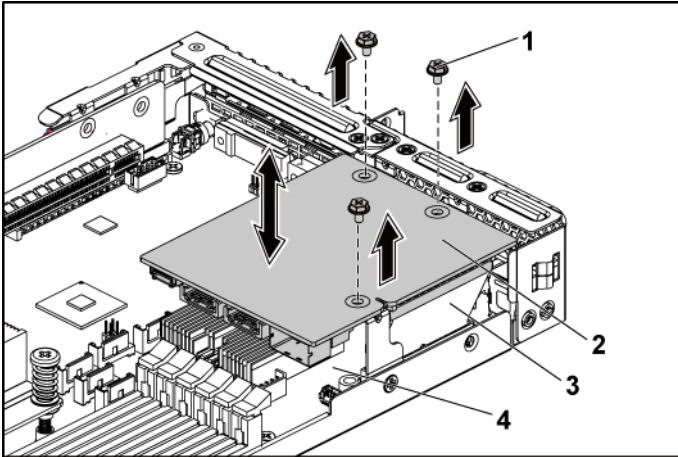

- | | | | |
|---|-------------------|---|-----------------------|
| 1 | screw (3) | 2 | SAS daughter card |
| 3 | card bridge board | 4 | system-board assembly |

Installing the SAS Daughter Card



CAUTION: Many repairs may only be done by a certified service technician. You should only perform troubleshooting and simple repairs as authorized in your product documentation, or as directed by the online or telephone service and support team. Damage due to servicing that is not authorized by Dell is not covered by your warranty. Read and follow the safety instructions that came with the product.

- 1 Place the daughter card on the system-board assembly. See Figure 3-22 and Figure 5-10.
- 2 Replace the screws that secure the daughter card. See Figure 3-22.
- 3 Reconnect all the cables to the daughter card. Make sure the cable is routed properly as shown in Figure 3-23.
- 4 Replace the system-board assembly. See "Installing a System-Board Assembly" on page 93.

Cable Routing for SAS Daughter Card

- 1 Connect the mini-SAS&SGPIO cable to the SAS daughter card, and connect the other end of the cable to the corresponding connectors on the interposer extender. See Figure 3-23 for the cable routing. See Figure 5-9 and Figure 5-10 for the interposer extender connectors and the SAS daughter card connectors.

Figure 3-23. Cable Routing for SAS Daughter Card

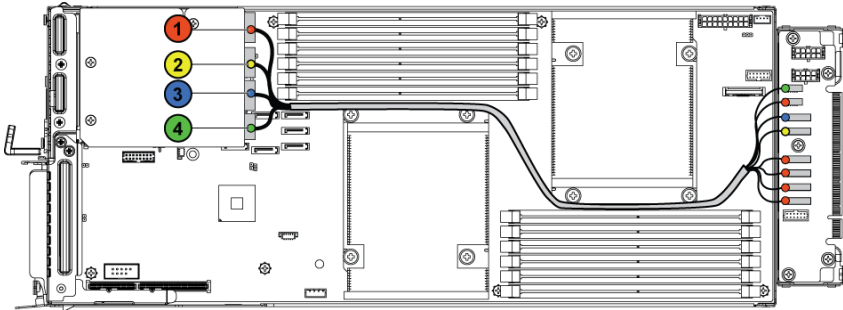

Item	Cable	From (SAS Daughter Card)	To (HDD to Backplane SATAII Connectors)
①	SAS/SGPIO cable	SAS_ports 0~3	SATAII connectors 1~4 and SGPIO A
②	SAS cable	SAS_port 4	SATAII connector 5
③	SAS cable	SAS_port 5	SATAII connector 6
④	SGPIO cable	SGPIO B	SGPIO B

Removing the NIC Daughter Card



CAUTION: Many repairs may only be done by a certified service technician. You should only perform troubleshooting and simple repairs as authorized in your product documentation, or as directed by the online or telephone service and support team. Damage due to servicing that is not authorized by Dell is not covered by your warranty. Read and follow the safety instructions that came with the product.

- 1 Remove the system-board assembly. See "Removing a System-Board Assembly" on page 92.
- 2 Disconnect all the cables from the NIC daughter card.
- 3 Remove the four screws that secure the expansion-card bracket. See Figure 3-24.
- 4 Lift the expansion-card bracket out of the system-board assembly. See Figure 3-24.

Figure 3-24. Removing and Installing the Expansion-Card Bracket

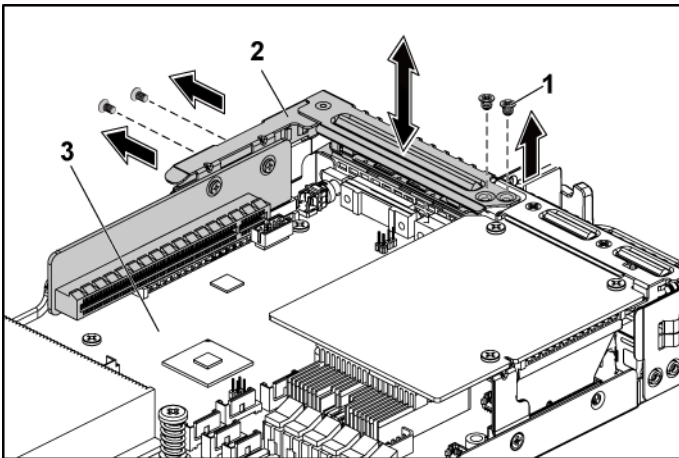

- 1 screw (4)
- 2 expansion-card bracket
- 3 system-board assembly

- 5 Remove the four screws that secure the NIC daughter card assembly. See Figure 3-25.
- 6 Lift the NIC daughter card assembly away from the card bridge board on the system board. See Figure 3-25.

Figure 3-25. Removing and Installing the NIC Daughter Card Assembly

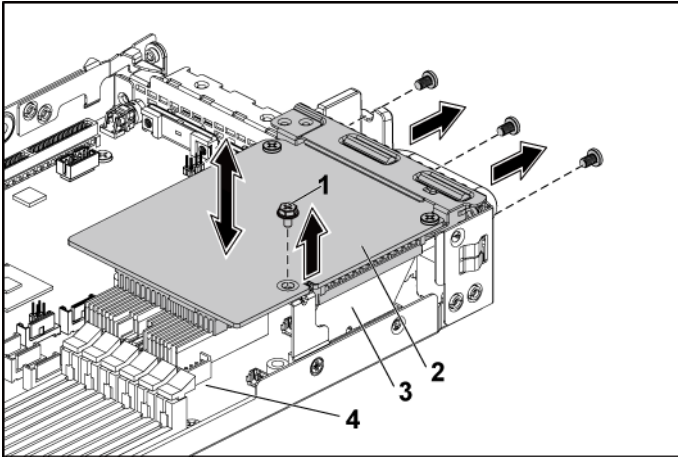

- | | | | |
|---|-------------------|---|----------------------------|
| 1 | screw (4) | 2 | NIC daughter card assembly |
| 3 | card bridge board | 4 | system-board assembly |

- 7 Remove the two screws that secure the NIC daughter card to the bracket. See Figure 3-26.
- 8 Remove the NIC daughter card from the bracket. See Figure 3-26.

Figure 3-26. Removing and Installing the NIC Daughter Card

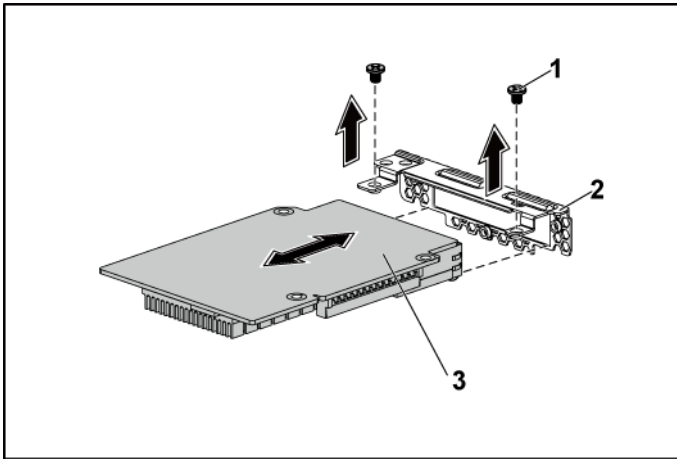

- 1 screw (2)
- 2 NIC daughter card bracket
- 3 NIC daughter card

Installing the NIC Daughter Card



CAUTION: Many repairs may only be done by a certified service technician. You should only perform troubleshooting and simple repairs as authorized in your product documentation, or as directed by the online or telephone service and support team. Damage due to servicing that is not authorized by Dell is not covered by your warranty. Read and follow the safety instructions that came with the product.

- 1 Attach the daughter card to the bracket by aligning the four NIC ports to the corresponding port slot on the bracket. See Figure 3-26 and Figure 5-11.
- 2 Install the two screws to secure the daughter card to the bracket. See Figure 3-26.
- 3 Install the NIC daughter card assembly to the card bridge board on the system-board assembly. See Figure 3-25.

- 4 Install the four screws to secure the NIC daughter card assembly to the system-board assembly. See Figure 3-25.
- 5 Place the expansion-card bracket into the system-board assembly.
- 6 Replace the four screws that secure the expansion-card bracket.
- 7 Reconnect all the cables to the NIC daughter card.
- 8 Replace the system-board assembly. See "Installing a System-Board Assembly" on page 93.

Removing the Mellanox Card



CAUTION: Many repairs may only be done by a certified service technician. You should only perform troubleshooting and simple repairs as authorized in your product documentation, or as directed by the online or telephone service and support team. Damage due to servicing that is not authorized by Dell is not covered by your warranty. Read and follow the safety instructions that came with the product.



NOTE: The Mellanox card comes with a different MLB tray, which is dedicated to the use of the card.

- 1 Remove the system-board assembly. See "Removing a System-Board Assembly" on page 92.
- 2 Disconnect all the cables from the Mellanox daughter card.
- 3 Remove the four screws that secure the expansion-card bracket. See Figure 3-27.
- 4 Lift the expansion-card bracket out of the system-board assembly. See Figure 3-24.

Figure 3-27. Removing and Installing the Expansion-Card Bracket

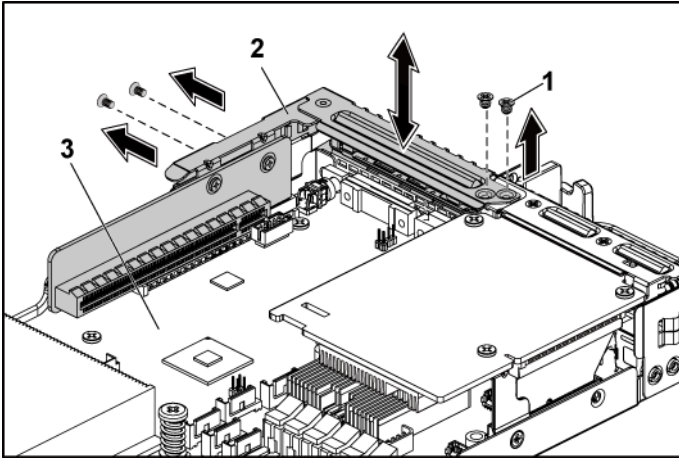

- 1 screw (4)
- 2 expansion-card bracket
- 3 system-board assembly

- 5 Remove the four screws that secure the Mellanox card assembly. See Figure 3-28.
- 6 Lift the Mellanox card assembly away from the mezzanine-card bridge board on the system board. See Figure 3-28.

Figure 3-28. Removing and Installing the Mellanox Card Assembly

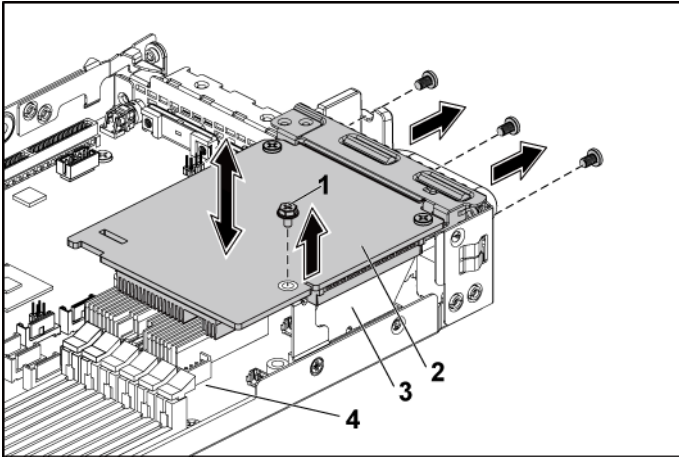

- | | | | |
|---|-------------------|---|------------------------|
| 1 | screw (4) | 2 | mellanox-card assembly |
| 3 | card bridge board | 4 | system-board assembly |

- 7 Remove the two screws that secure the Mellanox card to the bracket. See Figure 3-29.
- 8 Remove the Mellanox card from the bracket. See Figure 3-29.

Figure 3-29. Removing and Installing the Mellanox Card

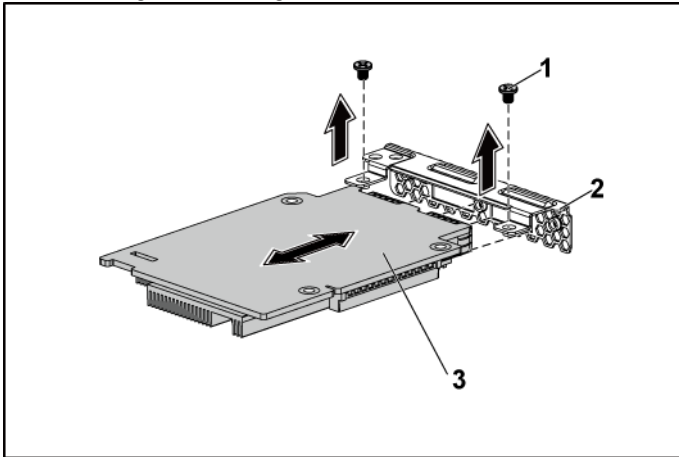

- 1 screw (2)
- 2 mellanox-card bracket
- 3 mellanox card

Installing the Mellanox Card



CAUTION: Many repairs may only be done by a certified service technician. You should only perform troubleshooting and simple repairs as authorized in your product documentation, or as directed by the online or telephone service and support team. Damage due to servicing that is not authorized by Dell is not covered by your warranty. Read and follow the safety instructions that came with the product.

- 1 Attach the daughter card to the bracket by aligning the two ports to the corresponding port slots on the bracket. See Figure 3-29.
- 2 Install the two screws to secure the Mellanox card to the bracket. See Figure 3-29.
- 3 Install the Mellanox card assembly to the card bridge board on the system-board assembly. See Figure 3-28.

- 4 Install the four screws to secure the Mellanox card assembly to the system-board assembly. See Figure 3-28.
- 5 Place the expansion-card bracket into the system-board assembly.
- 6 Replace the four screws that secure the expansion-card bracket.
- 7 Reconnect all the cables to the Mellanox card.
- 8 Replace the system-board assembly. See "Installing a System-Board Assembly" on page 93.

System Memory

Each system board has twelve unbuffered or registered DDR3-DIMM slots for the installation of up to twelve DDR3-800/1066/1333/1600* memory chips to support processor 0 and processor 1. See "System Board Connectors" on page 198 for the location of the memory modules.



NOTE: System memory working frequency is up to 1333MT/s only.

Supported DIMM Configuration

For the sequence of the twelve DIMM sockets, see Figure 3-30. When you insert the single rank/dual rank DIMM(s), always start with DIMMA2. See Table 3-2 for possible memory configurations.

Figure 3-30. Memory Slot Locations

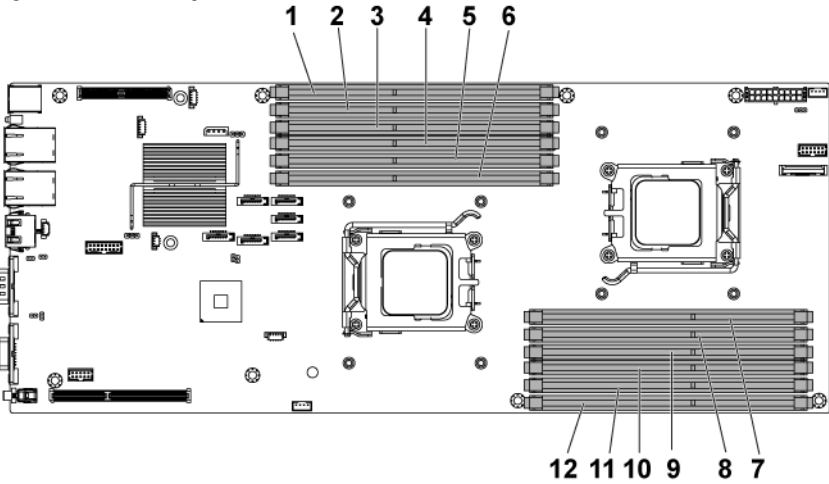

- | | | | |
|----|---------|----|---------|
| 1 | DIMM_C2 | 2 | DIMM_C1 |
| 3 | DIMM_C0 | 4 | DIMM_D2 |
| 5 | DIMM_D1 | 6 | DIMM_D0 |
| 7 | DIMM_B0 | 8 | DIMM_B1 |
| 9 | DIMM_B2 | 10 | DIMM_A0 |
| 11 | DIMM_A1 | 12 | DIMM_A2 |

Table 3-2. Memory Module Configurations

	DIMM	Processor 0					
		DIMM B0	DIMM B1	DIMM B2	DIMM A0	DIMM A1	DIMM A2
Single Rank/ Dual Rank	1**	–	–	–	–	–	✓
	2**	–	–	✓	–	–	✓
	2**	–	–	–	–	–	✓
	4	✓	–	✓	✓	–	✓
	4**	–	–	✓	–	–	✓
	6	✓	✓	✓	✓	✓	✓
	8	✓		✓	✓		✓
12*	✓	✓	✓	✓	✓	✓	
*Quad Rank	4	–	✓	–	–	✓	–

	DIMM	Processor 1					
		DIMM D0	DIMM D1	DIMM D2	DIMM C0	DIMM C1	DIMM C2
Single Rank/ Dual Rank	1**	–	–	–	–	–	–
	2**	–	–	–	–	–	–
	2**	–	–	–	–	–	✓
	4	–	–	–	–	–	–
	4**	–	–	✓	–	–	✓
	6	–	–	–	–	–	–
	8	✓	–	✓	✓	–	✓
	12*	✓	✓	✓	✓	✓	✓
*Quad Rank	4	–	✓	–	–	✓	–



NOTE: An empty DIMM socket is marked as “–”. For best performance, all the memory modules installed must be of the same speed, capacity, and from the same manufacturer.



NOTE: The Unbuffered DIMM does not support the configuration items marked as “**” in the table above.



NOTE: System memory working frequency is up to 1333MT/s only when 1R/2R 1600MHz UDIMM/RDIMM is installed, see the items marked as “***” in the table above.

Removing the Memory Modules



WARNING: The memory modules are hot to the touch for some time after the system has been powered down. Allow time for the memory modules to cool before handling them. Handle the memory modules by the card edges and avoid touching the components on the memory module.



CAUTION: Many repairs may only be done by a certified service technician. You should only perform troubleshooting and simple repairs as authorized in your product documentation, or as directed by the online or telephone service and support team. Damage due to servicing that is not authorized by Dell is not covered by your warranty. Read and follow the safety instructions that came with the product.

- 1 Remove the system-board assembly. See "Removing a System-Board Assembly" on page 92.
- 2 Locate the memory module sockets. See Figure 3-30.
- 3 Press down and out on the ejectors on each end of the socket until the memory module pops out of the socket. See Figure 3-31.
- 4 Handle each memory module only on either card edge, making sure not to touch the middle of the memory module.
- 5 Replace the system-board assembly. See "Installing a System-Board Assembly" on page 93.
- 6 Reconnect the system to the electrical outlet and turn the system on, including any attached peripherals.

Installing the Memory Modules



WARNING: The memory modules are hot to the touch for some time after the system has been powered down. Allow time for the memory modules to cool before handling them. Handle the memory modules by the card edges and avoid touching the components on the memory module.



CAUTION: Many repairs may only be done by a certified service technician. You should only perform troubleshooting and simple repairs as authorized in your product documentation, or as directed by the online or telephone service and support team. Damage due to servicing that is not authorized by Dell is not covered by your warranty. Read and follow the safety instructions that came with the product.

- 1 Remove the system-board assembly. See "Removing a System-Board Assembly" on page 92.
- 2 Locate the memory module sockets. See Figure 3-30.
- 3 Press the ejectors on the memory module socket down and out, as shown in Figure 3-31, to allow the memory module to be inserted into the socket.
- 4 Handle each memory module only on either card edge, making sure not to touch the middle of the memory module.

- 5 Align the memory module's edge connector with the alignment key of the memory module socket, and insert the memory module in the socket. See Figure 3-31.



NOTE: The memory module socket has an alignment key that allows you to install the memory module in the socket in only one way.

Figure 3-31. Installing and Removing a DIMM

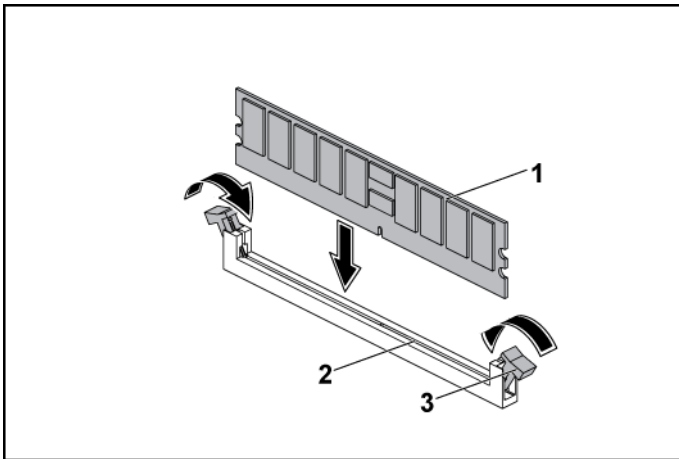

- | | | | |
|---|----------------------------------|---|----------------------|
| 1 | memory module | 2 | memory module socket |
| 3 | memory module socket ejector (2) | | |

- 6 Press down on the memory module with your thumbs to lock the memory module into the socket. See Figure 3-31.
When the memory module is properly seated in the socket, the ejectors on the memory module socket align with the ejectors on the other sockets that have memory modules installed.
- 7 Repeat step 4 through step 7 of this procedure to install the remaining memory modules in the approved configurations. See Table 3-2.
- 8 Replace the system-board assembly. See "Installing a System-Board Assembly" on page 93.

- 9 Start up the system, press <F2> to enter the System Setup program, and check the System Memory settings on the main System Setup screen.
The system should have already changed the value to reflect the newly installed memory.
- 10 If the value is incorrect, one or more of the memory modules may not be installed properly. Repeat step 2 through step 10 of this procedure, to ensure that the memory modules are firmly seated in their sockets.

Interposer Extenders



CAUTION: Many repairs may only be done by a certified service technician. You should only perform troubleshooting and simple repairs as authorized in your product documentation, or as directed by the online or telephone service and support team. Damage due to servicing that is not authorized by Dell is not covered by your warranty. Read and follow the safety instructions that came with the product.

Removing the Interposer Extender

- 1 Remove the system-board assembly. See "Removing a System-Board Assembly" on page 92.
- 2 Disconnect all the cables from the interposer extender. See Figure 5-9.
- 3 Remove the five screws that secure the interposer extender to the interposer-extender tray. See Figure 3-32.
- 4 Lift the interposer extender out of the interposer-extender tray. See Figure 3-32.

Figure 3-32. Removing and Installing the Interposer Extender

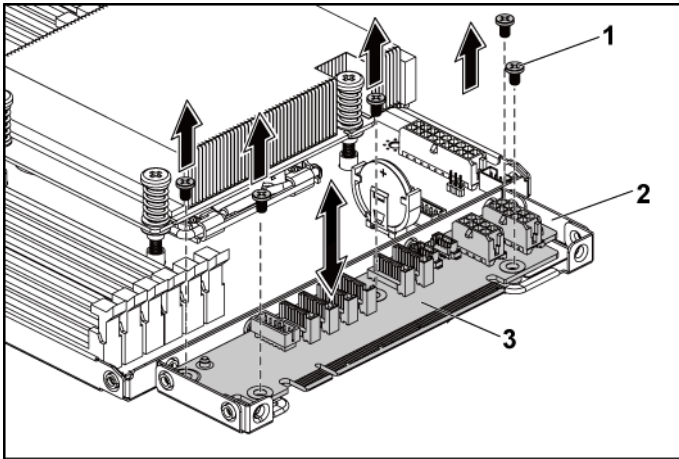

- | | | | |
|---|---------------------|---|--------------------------|
| 1 | screw (5) | 2 | interposer-extender tray |
| 3 | interposer extender | | |

Installing the Interposer Extender



CAUTION: Many repairs may only be done by a certified service technician. You should only perform troubleshooting and simple repairs as authorized in your product documentation, or as directed by the online or telephone service and support team. Damage due to servicing that is not authorized by Dell is not covered by your warranty. Read and follow the safety instructions that came with the product.

- 1 Place the interposer extender into the interposer-extender tray.
- 2 Replace the five screws that secure the interposer extender to the interposer-extender tray.
- 3 Connect all the cables to the interposer extender. See Figure 5-9.
- 4 Replace the system-board assembly. See "Installing a System-Board Assembly" on page 93.

System Battery

Replacing the System Battery



WARNING: There is a danger of a new battery exploding if it is incorrectly installed. Replace the battery only with the same or equivalent type recommended by the manufacturer. See your safety information for additional information.



CAUTION: Many repairs may only be done by a certified service technician. You should only perform troubleshooting and simple repairs as authorized in your product documentation, or as directed by the online or telephone service and support team. Damage due to servicing that is not authorized by Dell is not covered by your warranty. Read and follow the safety instructions that came with the product.

- 1 Remove the system-board assembly. See "Removing a System-Board Assembly" on page 92.

Figure 3-33. Replacing the System Battery

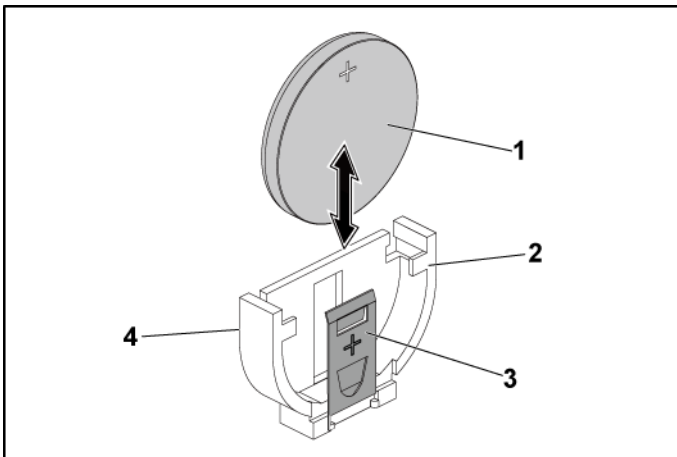

- | | | | |
|---|----------------|---|------------------------------------|
| 1 | system battery | 2 | positive side of battery connector |
| 3 | retention clip | 4 | negative side of battery connector |

- 2 Locate the battery location. See “System Board Connectors” on page 198.



CAUTION: To avoid damage to the battery connector, you must firmly support the connector while installing or removing a battery.

- 3 Gently pull the retention clip over the battery towards the positive side of the connector and lift the battery out of the connector. See Figure 3-33.
- 4 Hold the new battery with the “+” facing the retention clip on the battery connector. See Figure 3-33.
- 5 Gently pull the retention clip towards the positive side of the connector and slide the battery into the connector until the retention clip snaps into place. See Figure 3-33.
- 6 Replace the system-board assembly. See “Installing a System-Board Assembly” on page 93.
- 7 Enter the System Setup program to confirm that the battery is operating properly. See “Using the System Setup Program” on page 37.
- 8 Enter the correct time and date in the System Setup program’s **Time** and **Date** fields.
- 9 Exit the System Setup program.

System Board

Removing a System Board



CAUTION: Many repairs may only be done by a certified service technician. You should only perform troubleshooting and simple repairs as authorized in your product documentation, or as directed by the online or telephone service and support team. Damage due to servicing that is not authorized by Dell is not covered by your warranty. Read and follow the safety instructions that came with the product.

- 1 Remove the system-board assembly. See "Removing a System-Board Assembly" on page 92.
- 2 Remove the heat sink. See "Removing the Heat Sink" on page 94.
- 3 Remove the expansion-card assembly. See "Removing the Expansion Card" on page 99.
- 4 If installed, remove the SAS daughter card. See "Removing the SAS Daughter Card" on page 121.
- 5 Disconnect the hard drive and power cables from the system board.
- 6 Remove the eight screws and then slide the system board. See Figure 3-34.



CAUTION: Do not lift the system board by grasping a memory module, processor, or other components.

- 7 Grasp the system board by the edges and lift the system board away from the system-board assembly. See Figure 3-34.

Figure 3-34. Removing and Installing the System Board

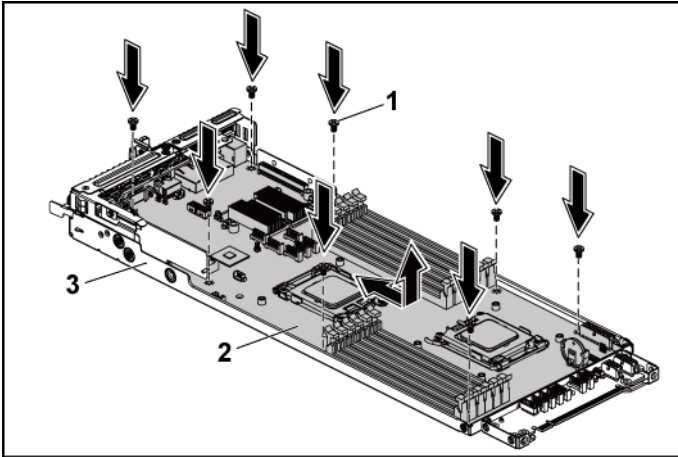

- 1 screw (8)
- 2 system board
- 3 system-board assembly

Installing a System Board

- 1 Unpack the new system board.
- 2 Holding the system board by the edges, slide the system board into the system-board assembly.
- 3 Replace the eight screws to secure the system board to the system-board assembly.
- 4 Transfer the processors to the new system board. See "Removing a Processor" on page 96 and "Installing a Processor" on page 97.
- 5 Remove the memory modules and transfer them to the same locations on the new board. See "Removing the Memory Modules" on page 133 and "Installing the Memory Modules" on page 134.
- 6 Connect the hard drive and power cables to the system board.

- 7 If applicable, install the SAS daughter card. See "Installing the SAS Daughter Card" on page 122.
- 8 Install the expansion-card assembly. See "Installing the Expansion Card" on page 101.
- 9 Replace the system-board assembly. See "Installing a System-Board Assembly" on page 93.

Opening and Closing the System



WARNING: Whenever you need to lift the system, get others to assist you. To avoid injury, do not attempt to lift the system by yourself.



CAUTION: This system must be operated with the system cover installed to ensure proper cooling.



CAUTION: Many repairs may only be done by a certified service technician. You should only perform troubleshooting and simple repairs as authorized in your product documentation, or as directed by the online or telephone service and support team. Damage due to servicing that is not authorized by Dell is not covered by your warranty. Read and follow the safety instructions that came with the product.

Opening the System

- 1 Recommend to turn off the system, including any attached peripherals, and disconnect the system from the electrical outlet.
- 2 Remove the securing screw from the system cover. See Figure 3-35.
- 3 Press the cover release latch lock. See Figure 3-35.
- 4 Grasp cover on both the sides with your palm on the traction pad, slide out and lift the cover away from the system. See Figure 3-35.

Figure 3-35. Opening and Closing the System

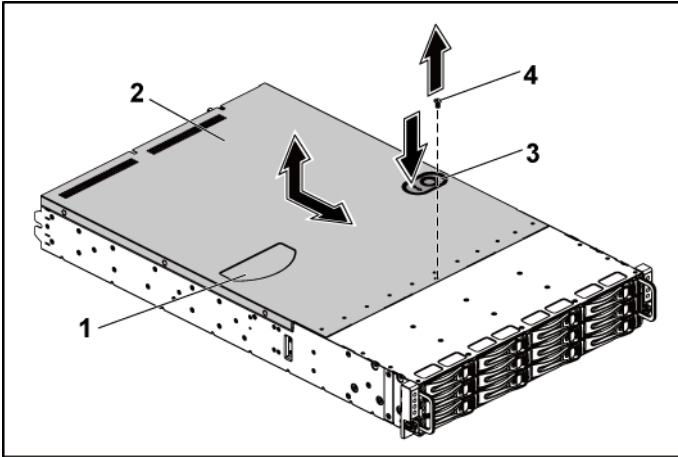

- | | | | |
|---|--------------------------|---|----------------|
| 1 | traction pad | 2 | system cover |
| 3 | cover release latch lock | 4 | securing screw |

Closing the System

- 1 Place the cover on the chassis and slide it to the front of the chassis until it snaps into place. See Figure 3-35.
- 2 Secure the cover with the securing screw. See Figure 3-35.

Cooling Fans

Removing a Cooling Fan



WARNING: Do not attempt to operate the system without the cooling fans.



WARNING: The cooling fan can continue to spin for some time after the system has been powered down. Allow time for the fan to stop spinning before removing it from the system.



CAUTION: Many repairs may only be done by a certified service technician. You should only perform troubleshooting and simple repairs as authorized in your product documentation, or as directed by the online or telephone service and support team. Damage due to servicing that is not authorized by Dell is not covered by your warranty. Read and follow the safety instructions that came with the product.

- 1 Recommend to turn off the system, including any attached peripherals, and disconnect the system from its electrical outlet.
- 2 Open the system. See "Opening the System" on page 142.
- 3 Disconnect the fan's power cable from the fan-controller board.
Note the routing of the cable through the tabs on the chassis as you remove them from the system. You must route these cables properly when you replace them to prevent the cables from being pinched or crimped.
- 4 To remove the cooling fan 2, 3 or 4, just directly lift it out of the cooling-fan cage. See Figure 3-36.

Figure 3-36. Removing and Installing a Cooling Fan 2, 3 or 4

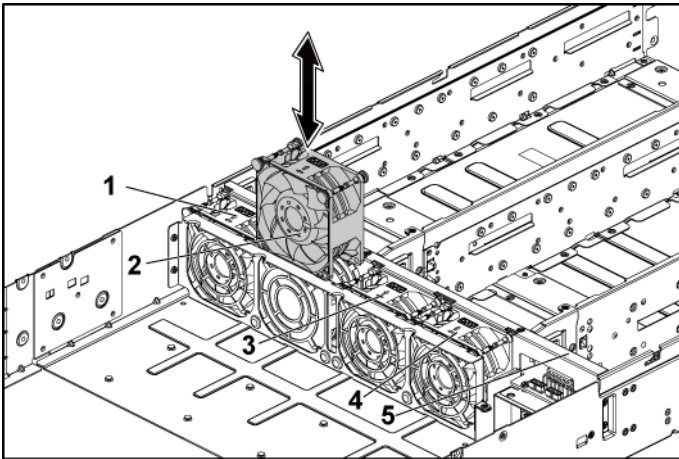

- | | | | |
|---|------------------|---|---------------|
| 1 | cooling fan 1 | 2 | cooling fan 2 |
| 3 | cooling fan 3 | 4 | cooling fan 4 |
| 5 | cooling-fan cage | | |

- 5 To completely remove the cooling fan 1, please follow step 6 to 8.
- 6 First lift the cooling fan 1 out of the cooling fan brackets. See Figure 3-37.
- 7 Remove the screws that secure the short cooling-fan bracket to the chassis, and then lift the short cooling-fan bracket out of the chassis. See Figure 3-37.
Note the cooling fan 1 cable which is routed under the short cooling-fan bracket.
- 8 Lift the cooling fan 1 with the cable out of the chassis.

Figure 3-37. Removing and Installing the Cooling-Fan 1

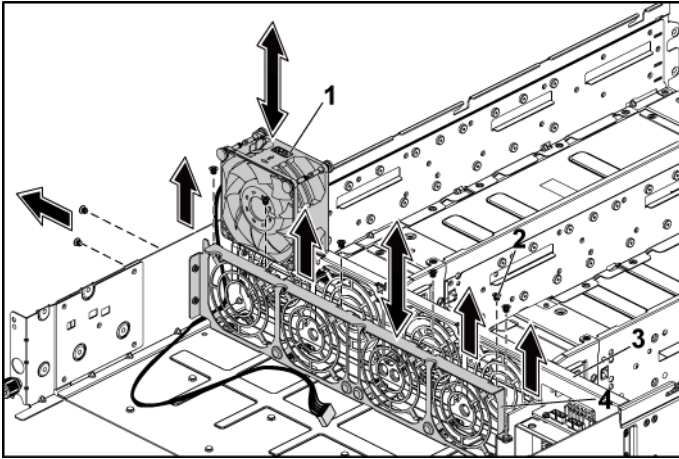

- | | | | |
|---|----------------------------|---|-----------------------------|
| 1 | cooling fan 1 | 2 | screw (8) |
| 3 | cooling fan bracket (long) | 4 | cooling fan bracket (short) |

Installing a Cooling Fan



CAUTION: Many repairs may only be done by a certified service technician. You should only perform troubleshooting and simple repairs as authorized in your product documentation, or as directed by the online or telephone service and support team. Damage due to servicing that is not authorized by Dell is not covered by your warranty. Read and follow the safety instructions that came with the product.

- 1 To install the cooling fan 1, align the cooling fan 1 and slide it in the cooling-fan cage with the cooling fan 1 cable routed under the cooling-fan bracket; and then install the short cooling-fan bracket into the chassis. See Figure 3-36 and Figure 3-37.
- 2 To install the cooling fan 2, 3 or 4, align the cooling fan and slide it in the cooling-fan cage until the cooling fan is firmly seated. See Figure 3-36.



NOTE: The fan blades should face the front panel of the system.

- 3 Connect the fan's power cable to the connector on the fan-controller board.

You must route these cables properly through the tabs on the chassis to prevent them from being pinched or crimped.

- 4 Close the system. See "Closing the System" on page 143.
- 5 Reconnect the system to its electrical outlet and turn on the system, including any attached peripherals.

Power Distribution Boards

Removing a Power Distribution Board



CAUTION: Many repairs may only be done by a certified service technician. You should only perform troubleshooting and simple repairs as authorized in your product documentation, or as directed by the online or telephone service and support team. Damage due to servicing that is not authorized by Dell is not covered by your warranty. Read and follow the safety instructions that came with the product.



NOTE: This system has two power distribution boards. The procedure to remove and install both the power distribution boards is similar. To access the second power distribution board at the bottom, remove the power distribution board at the top.

- 1 Recommend to turn off the system, including any attached peripherals, and disconnect the system from its electrical outlet.
- 2 Open the system. See "Opening the System" on page 142.
- 3 Remove the power supply. See "Removing and Installing a Power Supply" on page 91.

- 4 Disconnect all the cables from the first power distribution board. See Figure 3-39.

Note the routing of the cable underneath the tabs on the chassis as you remove them from the system. You must route these cables properly when you replace them to prevent the cables from being pinched or crimped.

- 5 Remove the screws securing the first power distribution board to the system. See Figure 3-38.
- 6 Lift the power distribution board out of the system. See Figure 3-38.



NOTE: To remove the second power distribution board that is below the first power distribution board, remove the power distribution board connector and angle the board before lifting.

Figure 3-38. Removing and Installing a Power Distribution Board

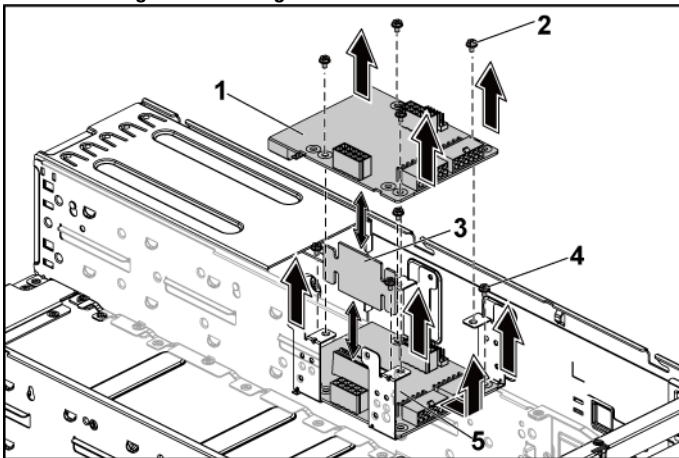

- | | | | |
|---|------------------------------------|---|-----------|
| 1 | 1st power distribution board | 2 | screw (4) |
| 3 | power distribution board-connector | 4 | screw (4) |
| 5 | 2nd power distribution board | | |

Installing a Power Distribution Board



CAUTION: Many repairs may only be done by a certified service technician. You should only perform troubleshooting and simple repairs as authorized in your product documentation, or as directed by the online or telephone service and support team. Damage due to servicing that is not authorized by Dell is not covered by your warranty. Read and follow the safety instructions that came with the product.



CAUTION: If removed, you must replace the second power distribution board at the bottom and the power distribution board-connector before replacing the first power distribution board at the top.

- 1 If removed, first place the second power distribution board in the system. See Figure 3-38. Otherwise skip to step 5.



NOTE: To install the second power distribution board that is below the first power distribution board, angle the board during installation.

- 2 Replace the screws securing the second power distribution board to the system. See Figure 3-38.
- 3 Replace the power distribution board-connector. See Figure 3-38.
- 4 Connect all the cables to the second power distribution board. See Figure 3-39.

You must route these cables properly through the tabs on the chassis to prevent them from being pinched or crimped.

- 5 Replace the first power distribution board in the system. See Figure 3-38.
- 6 Replace the screws securing the first power distribution board to the system. See Figure 3-38.
- 7 Connect all the cables to the first power distribution board. See Figure 3-39.

You must route these cables properly through the tabs on the chassis to prevent them from being pinched or crimped.

- 8 Replace the power supply. See "Installing a Power Supply" on page 91.

- 9 Close the system. See "Closing the System" on page 143.
- 10 Reconnect the system to its electrical outlet and turn on the system, including any attached peripherals.

Cable Routing for Power Distribution Board

Figure 3-39. Cable Routing–Power Distribution Board

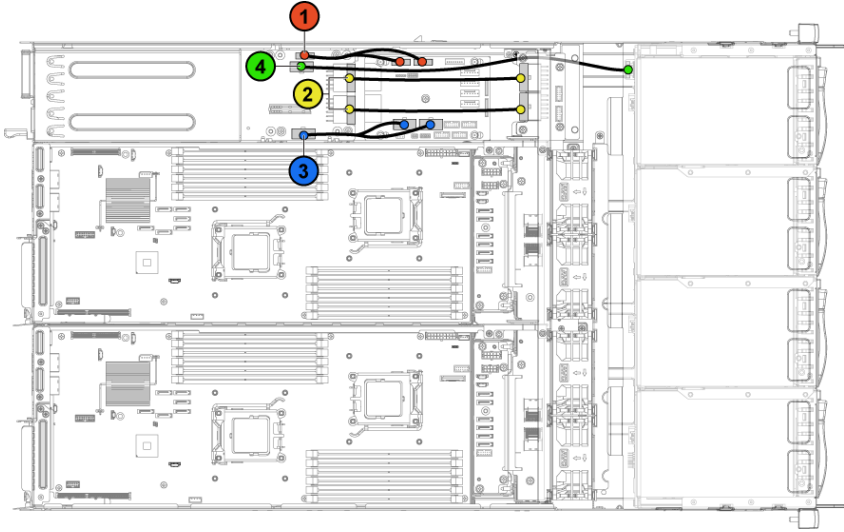

Item	Cable	From (Power Distribution Boards)	To
1	PMBus to power distribution board cables	PMBus connectors (J6)	Fan Control Board
2	Main power cables	Main power connectors (J2, J3)	Middle Plane

Item	Cable	From (Power Distribution Boards)	To
3	System fan board power cables	System fan board power connectors (J7)	Fan Control Board
4	Hard-drive backplane power cables	Hard-drive backplane power connectors (J5)	Backplane

Fan Controller Board

Removing the Fan Controller Board



CAUTION: Many repairs may only be done by a certified service technician. You should only perform troubleshooting and simple repairs as authorized in your product documentation, or as directed by the online or telephone service and support team. Damage due to servicing that is not authorized by Dell is not covered by your warranty. Read and follow the safety instructions that came with the product.

- 1 Recommend to turn off the system, including any attached peripherals, and disconnect the system from its electrical outlet.
- 2 Open the system. See "Opening the System" on page 142.
- 3 Remove the power distribution boards. See "Removing a Power Distribution Board" on page 147.
- 4 Disconnect all the cables from the fan controller board. See Figure 3-41. Note the routing of the cable underneath the tabs on the chassis as you remove them from the system. You must route these cables properly when you replace them to prevent the cables from being pinched or crimped.

- 5 Remove the screw securing the fan controller board to the chassis. See Figure 3-40.
- 6 Slide and lift the fan controller board out of the chassis. See Figure 3-40.

Figure 3-40. Removing and Installing the Fan Controller Board

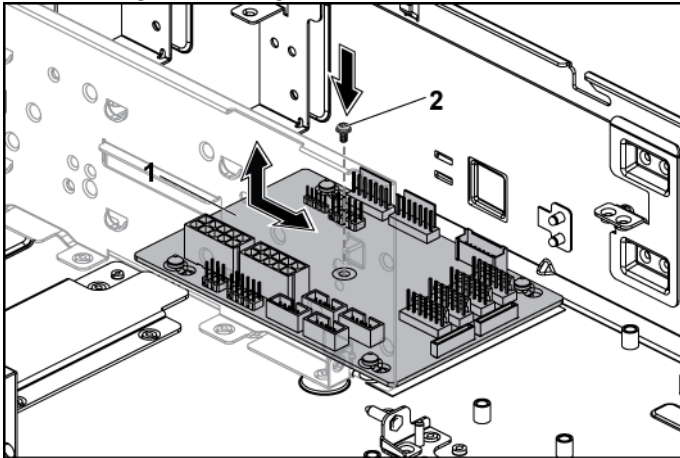

1 fan controller board

2 screw

Installing the Fan Controller Board



CAUTION: Many repairs may only be done by a certified service technician. You should only perform troubleshooting and simple repairs as authorized in your product documentation, or as directed by the online or telephone service and support team. Damage due to servicing that is not authorized by Dell is not covered by your warranty. Read and follow the safety instructions that came with the product.

- 1 Place the fan controller board into the chassis and slide it into place. See Figure 3-40.

- 2 Replace the screw to secure the fan controller board to the chassis. See Figure 3-40.
- 3 Connect all the cables to the fan controller board. See Figure 3-41. You must route these cables properly through the tabs on the chassis to prevent them from being pinched or crimped.
- 4 Replace the power distribution boards. See "Installing a Power Distribution Board" on page 149.
- 5 Close the system. See "Closing the System" on page 143.
- 6 Reconnect the system to its electrical outlet and turn on the system, including any attached peripherals.

Cable Routing for Fan Control Board

Figure 3-41. Cable Routing–Fan Control Board

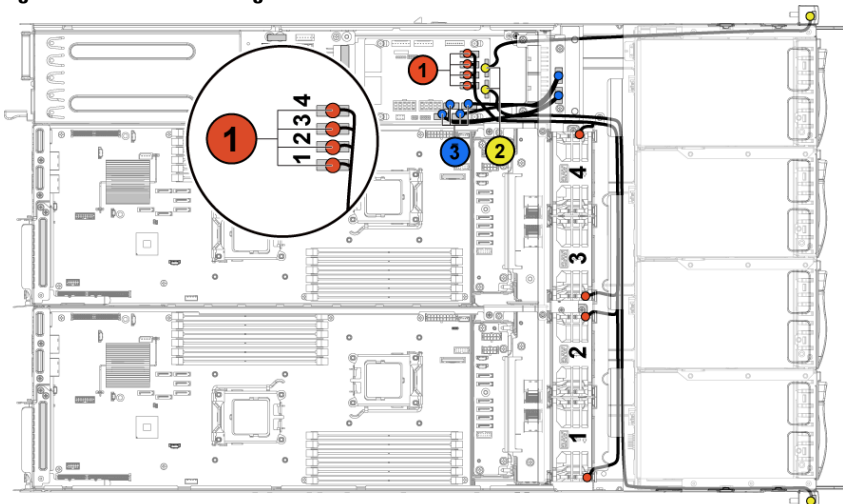

Item	Cable	From (Fan Control Board)	To
①	System fan cables	System fan connectors (J12, J19, J11, J16)	System fans
②	Front panel cables	Front-panel connectors (J31, J32)	Front panels
③	Front panel to system board cables	Front-panel connectors for system board (J23, J24)	Middle Planes

Middle Planes

Removing the Middle Planes



CAUTION: Many repairs may only be done by a certified service technician. You should only perform troubleshooting and simple repairs as authorized in your product documentation, or as directed by the online or telephone service and support team. Damage due to servicing that is not authorized by Dell is not covered by your warranty. Read and follow the safety instructions that came with the product.

- 1 Turn off the system, including any attached peripherals, and disconnect the system from its electrical outlet.
- 2 Open the system. See "Opening the System" on page 142.
- 3 Remove the system-board assemblies. See "Removing a System-Board Assembly" on page 92.
- 4 Remove the cooling fans. See "Removing a Cooling Fan" on page 144.

- 5 Remove the screws that secure the cooling-fan brackets to the chassis. See Figure 3-42.
- 6 Lift the cooling-fan brackets out of the chassis. See Figure 3-42.

Figure 3-42. Removing and Installing the Cooling-Fan Brackets

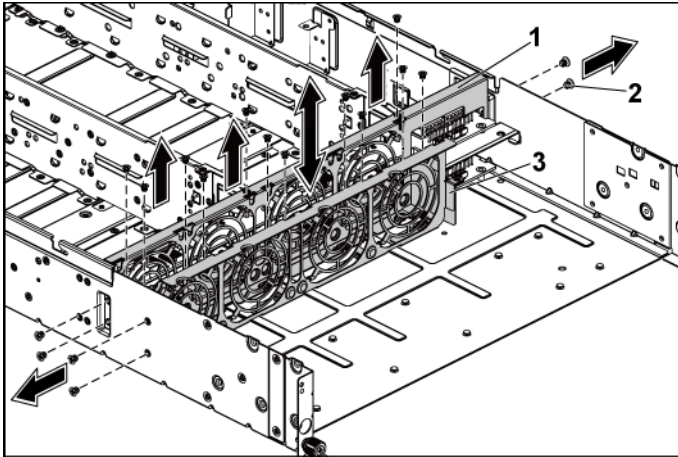

- | | | | |
|---|-----------------------------|---|------------|
| 1 | cooling fan bracket (long) | 2 | Screw (14) |
| 3 | cooling fan bracket (short) | | |

- 7 Disconnect all the cables from the upper middle plane. See Figure 5-9. Note the routing of the cable underneath the tabs on the chassis as you remove them from the system. You must route these cables properly when you replace them to prevent the cables from being pinched or crimped.
- 8 Remove the screws that secure the upper middle plane to the middle plane holder. Figure 3-43.
- 9 Lift the upper middle plane out. See Figure 3-43.

Figure 3-43. Removing and Installing the Upper Middle Plane

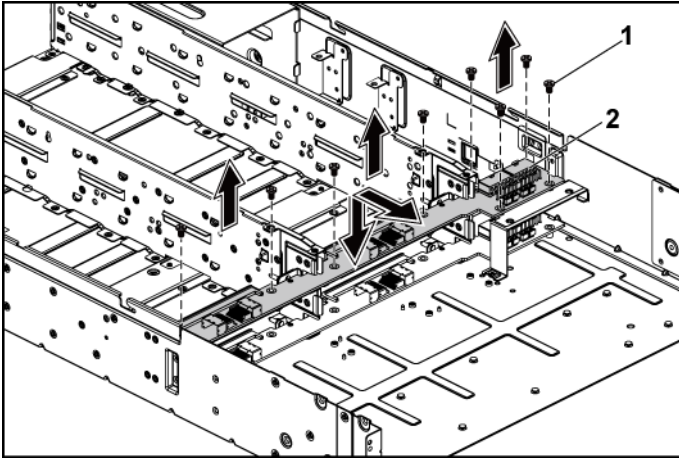

1 screw (9)

2 upper middle plane

10 Remove the screws that secure the mid-plane holder support to the chassis. See Figure 3-44.

11 Lift the mid-plane holder support out of the chassis. See Figure 3-44.

Figure 3-44. Removing and Installing the Mid-plane Holder Support

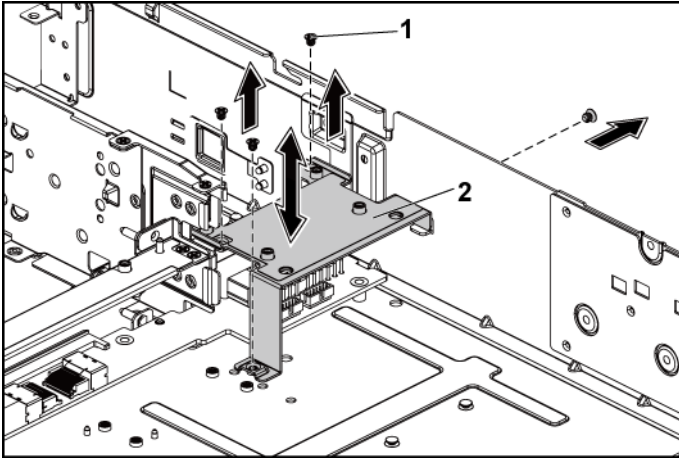

1 screw (4)

2 mid-plane holder support

12 Remove the screws that secure the mid-plane holder to the chassis.
Figure 3-45.

13 Lift the mid-plane holder out of the chassis. See Figure 3-45.

Figure 3-45. Removing and Installing the Mid-plane Holder

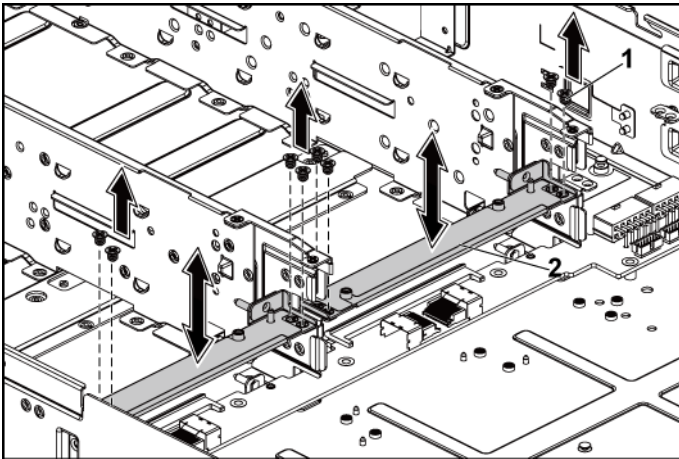

1 screw (8)

2 mid-plane holder

- 14 Disconnect all the cables from the lower middle plane. See Figure 5-9. Note the routing of the cable underneath the tabs on the chassis as you remove them from the system. You must route these cables properly when you replace them to prevent the cables from being pinched or crimped.
- 15 Remove the screws that secure the lower middle plane to the chassis. Figure 3-46.
- 16 Lift the lower middle plane out of the chassis. See Figure 3-46.

Figure 3-46. Removing and Installing the Lower Middle Plane

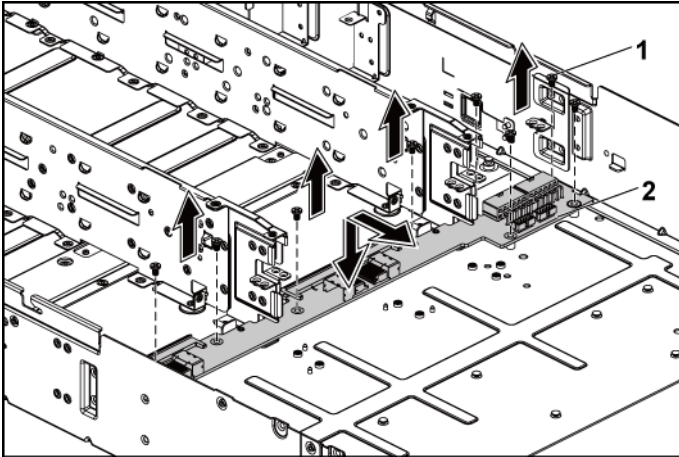

1 screw (8)

2 lower middle plane

Installing the Middle Planes



CAUTION: Many repairs may only be done by a certified service technician. You should only perform troubleshooting and simple repairs as authorized in your product documentation, or as directed by the online or telephone service and support team. Damage due to servicing that is not authorized by Dell is not covered by your warranty. Read and follow the safety instructions that came with the product.

- 1 Place the lower middle plane into the chassis. See Figure 3-46.
- 2 Replace the screws that secure the lower middle plane to the chassis. See Figure 3-46.
- 3 Connect all the cables to the lower middle plane. See Figure 5-9. You must route these cables properly through the tabs on the chassis to prevent them from being pinched or crimped.
- 4 Place the middle-plane holder into the chassis. See Figure 3-45.

- 5 Replace the screws that secure the middle-plane holder to the chassis. See Figure 3-45.
- 6 Place the mid-plane holder support into the chassis. See Figure 3-44.
- 7 Replace the screws that secure the mid-plane holder support to the chassis. See Figure 3-44.
- 8 Place the upper middle plane on the middle-plane holder. See Figure 3-43.
- 9 Replace the screws that secure the middle plane to the middle-plane holder. See Figure 3-43.
- 10 Connect all the cables to the upper middle plane. See Figure 5-9.
You must route these cables properly through the tabs on the chassis to prevent them from being pinched or crimped.
- 11 Place the fan bracket into the chassis. Figure 3-42.
- 12 Replace the screws that secure the fan bracket to the chassis. Figure 3-42.
- 13 Replace the cooling fans. See "Installing a Cooling Fan" on page 146.
- 14 Replace the system-board assemblies. See "Installing a System-Board Assembly" on page 93.
- 15 Close the system, see "Closing the System" on page 143.
- 16 Reconnect the system to its electrical outlet and turn on the system, including any attached peripherals.

Backplanes



NOTE: Following is the replacement procedure of SATA2 and SAS backplane for 3.5-inch hard drive systems. Replacement procedures for the 2.5-inch SATA2 and SAS backplanes are similar to the procedures to replace backplane for 3.5-inch hard drive systems.

Removing the Backplane



CAUTION: Many repairs may only be done by a certified service technician. You should only perform troubleshooting and simple repairs as authorized in your product documentation, or as directed by the online or telephone service and support team. Damage due to servicing that is not authorized by Dell is not covered by your warranty. Read and follow the safety instructions that came with the product.

- 1 Recommend to turn off the system, including any attached peripherals, and disconnect the system from its electrical outlet.
- 2 Remove all the hard drives. See “Removing a Hard-Drive Carrier” on page 85.



CAUTION: To prevent damage to the drives and backplane, you must remove the hard drives from the system before removing the backplane.



CAUTION: You must note the number of each hard drive and temporarily label them before removal so that you can replace them in the same locations.

- 3 Open the system. See "Opening the System" on page 142.
- 4 Remove the screws that secure the hard-drive cage to the chassis. See Figure 3-47.

Figure 3-47. Removing and Installing the Backplane

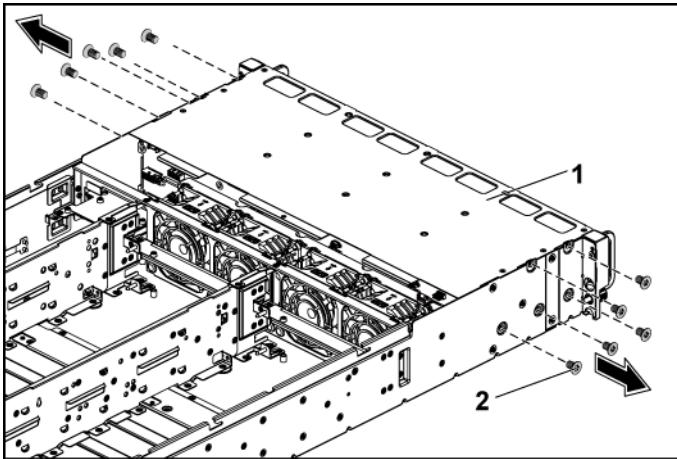

1 hard-drive cage

2 screw (10)

- 5 Remove the screws that secure the front-panel assemblies to the chassis. See Figure 3-48.
- 6 Disconnect all the cables from the backplane. See Figure 5-3 for 3.5-inch hard drives and Figure 5-5 for 2.5-inch hard drives. Note the routing of the cable underneath the tabs on the chassis as you remove them from the system. You must route these cables properly when you replace them to prevent the cables from being pinched or crimped.
- 7 Disconnect front panel cables from the fan controller board. See Figure 5-12. Note the routing of the cable underneath the tabs on the chassis as you remove them from the system. You must route these cables properly when you replace them to prevent the cables from being pinched or crimped.

- 8 Remove the hard-drive cage from the chassis. See Figure 3-48 See Figure 3-48.

Figure 3-48. Removing and Installing the Hard-Drive Cage

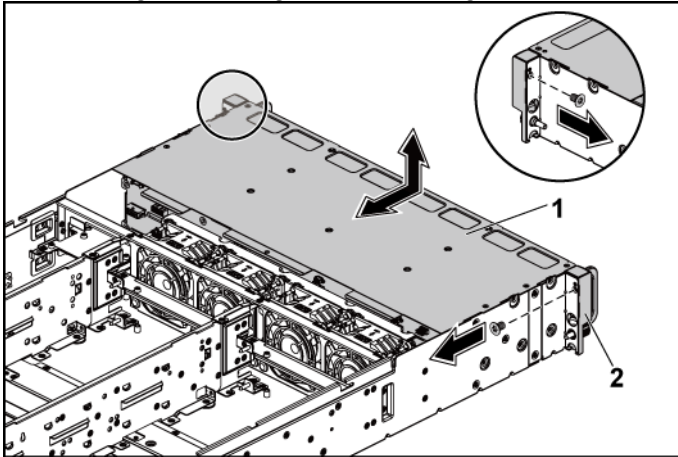

- | | | | |
|---|-----------------|---|--------------------------|
| 1 | hard-drive cage | 2 | front-panel assembly (2) |
|---|-----------------|---|--------------------------|

- 9 Remove the screws that secure the backplane to the hard-drive cage. See Figure 3-49.
- 10 Remove the backplane from the hard-drive cage. See Figure 3-49.

Figure 3-49. Removing and Installing the Backplane From the Hard-Drive Cage

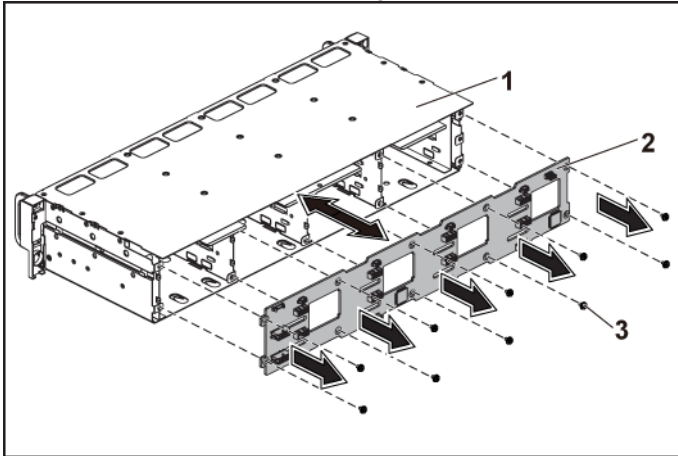

- | | | | |
|---|-----------------|---|-----------|
| 1 | hard-drive cage | 2 | backplane |
| 3 | screw (10) | | |

Installing the Backplane



CAUTION: Many repairs may only be done by a certified service technician. You should only perform troubleshooting and simple repairs as authorized in your product documentation, or as directed by the online or telephone service and support team. Damage due to servicing that is not authorized by Dell is not covered by your warranty. Read and follow the safety instructions that came with the product.

- 1 Install the backplane into the hard-drive cage. See Figure 3-49.
- 2 Replace the screws that secure the backplane to the hard-drive cage. See Figure 3-49.
- 3 Replace the hard-drive cage into the chassis. See Figure 3-48.
- 4 Replace the screws that secure the front-panel assemblies to the chassis. See Figure 3-48.

- 5 Connect all the cables to the backplane. See Figure 5-3 for 3.5-inch hard drives and Figure 5-5 for 2.5-inch hard drives.
You must route these cables properly through the tabs on the chassis to prevent them from being pinched or crimped.
- 6 Connect front panel cables to the fan controller board. See Figure 5-12.
You must route these cables properly through the tabs on the chassis to prevent them from being pinched or crimped.
- 7 Replace the screws that secure the hard-drive cage. See Figure 3-47.
- 8 Close the system, see "Closing the System" on page 143.
- 9 Replace the hard drives. See "Installing a Hard Drive into a Hard-Drive Carrier" on page 88.
- 10 Reconnect the system to its electrical outlet and turn on the system, including any attached peripherals.

Expander Card (Optional)

The information in this section applies only to two system-board systems with the 2.5-inch SATA2 and SAS backplane.

Removing the Expander Card



CAUTION: Many repairs may only be done by a certified service technician. You should only perform troubleshooting and simple repairs as authorized in your product documentation, or as directed by the online or telephone service and support team. Damage due to servicing that is not authorized by Dell is not covered by your warranty. Read and follow the safety instructions that came with the product.

- 1 Recommend to turn off the system, including any attached peripherals, and disconnect the system from its electrical outlet.
- 2 Remove all the hard drives. See "Removing a Hard-Drive Carrier" on page 85.

- △ **CAUTION:** To prevent damage to the drives and backplane, you must remove the hard drives from the system before removing the backplane.
 - △ **CAUTION:** You must note the number of each hard drive and temporarily label them before removal so that you can replace them in the same locations.
- 3 Open the system. See "Opening the System" on page 142.
 - 4 Remove the screws that secure the hard-drive cage to the chassis. See Figure 3-50.

Figure 3-50. Removing and Installing the 2.5-inch Hard-Drive Backplane

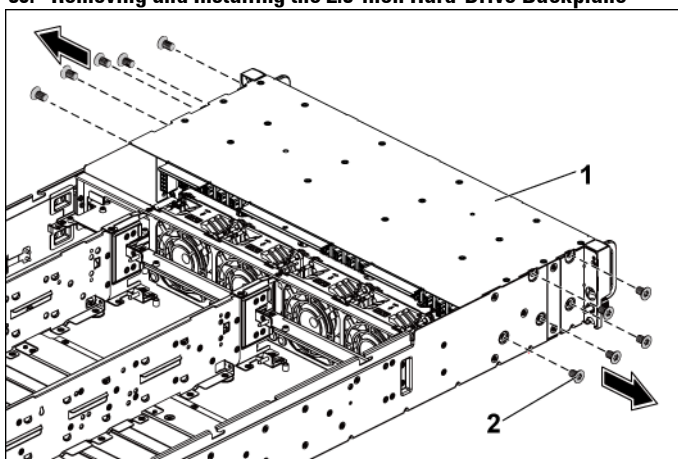

1 hard-drive cage

2 screw (10)

- 5 Remove the screws that secure the front-panel assemblies to the chassis. See Figure 3-50.
- 6 Disconnect all the cables from the backplane. See Figure 5-6 for 2.5-inch hard drives.

Note the routing of the cable underneath the tabs on the chassis as you remove them from the system. You must route these cables properly when you replace them to prevent the cables from being pinched or crimped.

- 7 Disconnect all the cables from the expander card. See Figure 5-7.
Note the routing of the cable underneath the tabs on the chassis as you remove them from the system. You must route these cables properly when you replace them to prevent the cables from being pinched or crimped.
- 8 Disconnect front panel cables from the fan controller board. See Figure 5-12.
Note the routing of the cable underneath the tabs on the chassis as you remove them from the system. You must route these cables properly when you replace them to prevent the cables from being pinched or crimped.
- 9 Remove the hard-drive cage from the chassis. See Figure 3-51.

Figure 3-51. Removing and Installing the Hard-Drive Cage

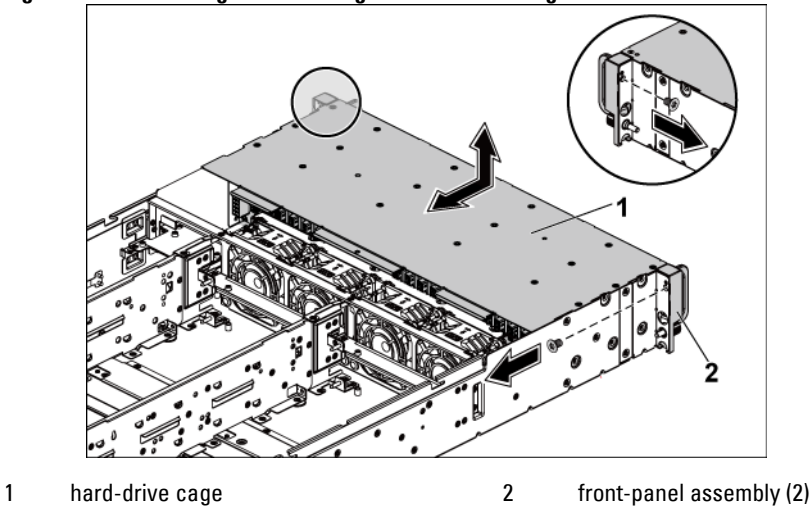

- 10 Remove the screws that secure the backplane to the hard-drive cage.
See Figure 3-52.
- 11 Remove the backplane with the expander card from the hard-drive cage.
See Figure 3-52.

Figure 3-52. Removing and Installing the Backplane with the Expander Card From the Hard-Drive Cage

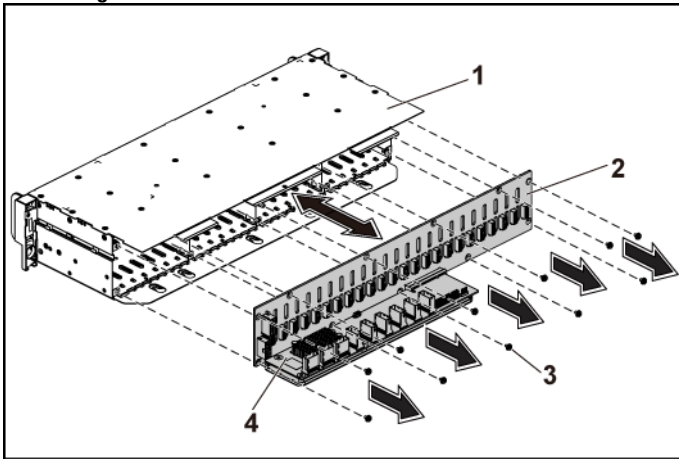

- | | | | |
|---|-----------------|---|-------------------------------|
| 1 | hard-drive cage | 2 | 2.5-inch hard-drive backplane |
| 3 | screw (10) | 4 | expander card |

- 12 Remove the expander card from the 2.5-inch hard-drive backplane. See Figure 3-53.

Figure 3-53. Removing and Installing the Expander Card From the Backplane

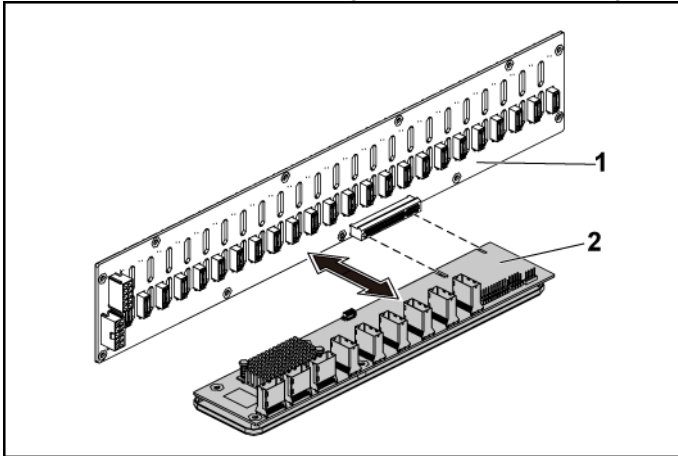

- 1 2.5-inch hard-drive backplane 2 expander card

Installing the Expander Card



CAUTION: Many repairs may only be done by a certified service technician. You should only perform troubleshooting and simple repairs as authorized in your product documentation, or as directed by the online or telephone service and support team. Damage due to servicing that is not authorized by Dell is not covered by your warranty. Read and follow the safety instructions that came with the product.

- 1 Install the expander card into the 2.5-inch hard-drive backplane. See Figure 3-53.
- 2 Install the 2.5-inch hard-drive backplane into the hard-drive cage. See Figure 3-52.
- 3 Replace the screws that secure the backplane to the hard-drive cage. See Figure 3-52.
- 4 Replace the hard-drive cage into the chassis. See Figure 3-51.

- 5 Replace the screws that secure the front-panel assemblies to the chassis. See Figure 3-51.
- 6 Connect all the cables to the backplane. See Figure 5-5 for 2.5-inch hard drives.
You must route these cables properly through the tabs on the chassis to prevent them from being pinched or crimped.
- 7 Connect all the cables to the expander card. See Figure 5-7.
You must route these cables properly through the tabs on the chassis to prevent them from being pinched or crimped.
- 8 Connect front panel cables to the fan controller board. See Figure 3-41.
You must route these cables properly through the tabs on the chassis to prevent them from being pinched or crimped.
- 9 Replace the screws that secure the hard-drive cage. See Figure 3-50.
- 10 Close the system, see "Closing the System" on page 143.
- 11 Replace the hard drives. See "Installing a Hard Drive into a Hard-Drive Carrier" on page 88.
- 12 Reconnect the system to its electrical outlet and turn on the system, including any attached peripherals.

Front Panels

Removing the Front Panel



CAUTION: Many repairs may only be done by a certified service technician. You should only perform troubleshooting and simple repairs as authorized in your product documentation, or as directed by the online or telephone service and support team. Damage due to servicing that is not authorized by Dell is not covered by your warranty. Read and follow the safety instructions that came with the product.

- 1 Turn off the system, including any attached peripherals, and disconnect the system from the electrical outlet.
- 2 Remove all the hard drives. See "Removing a Hard-Drive Carrier" on page 85.



CAUTION: To prevent damage to the drives and backplane, you must remove the hard drives from the system before removing the backplane.



CAUTION: You must note the number of each hard drive and temporarily label them before removal so that you can replace them in the same locations.

- 3 Open the system. See "Opening the System" on page 142.
- 4 Disconnect all the cables from the backplane. See Figure 5-3 for 3.5-inch hard drives and Figure 5-6 for 2.5-inch hard drives.
Note the routing of the cable underneath the tabs on the chassis as you remove them from the system. You must route these cables properly when you replace them to prevent the cables from being pinched or crimped.
- 5 Disconnect front panel cables from the fan controller board. See Figure 5-12.
Note the routing of the cable underneath the tabs on the chassis as you remove them from the system. You must route these cables properly when you replace them to prevent the cables from being pinched or crimped.
- 6 Remove the screws that secure the hard-drive cage to the chassis. See Figure 3-47.
- 7 Remove the screws that secure the front-panel assemblies to the chassis. See Figure 3-48.
- 8 Remove the hard-drive cage from the chassis. See Figure 3-48.
- 9 Remove the screws that secure the front-panel assembly to the hard-drive cage. See Figure 3-54.
- 10 Remove the front-panel assembly from the hard-drive cage. See Figure 3-54.

Figure 3-54. Removing and Installing a Front Panel Assembly

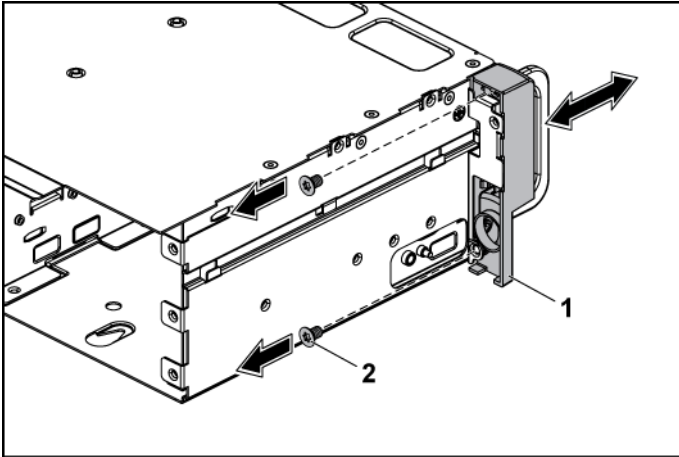

1 front-panel assembly

2 screw (2)

- 11 Push aside the retention hooks on the front-panel assembly. See Figure 3-55.
- 12 Remove the front panel from the front-panel assembly. See Figure 3-55.

Figure 3-55. Removing and Installing a Front Panel

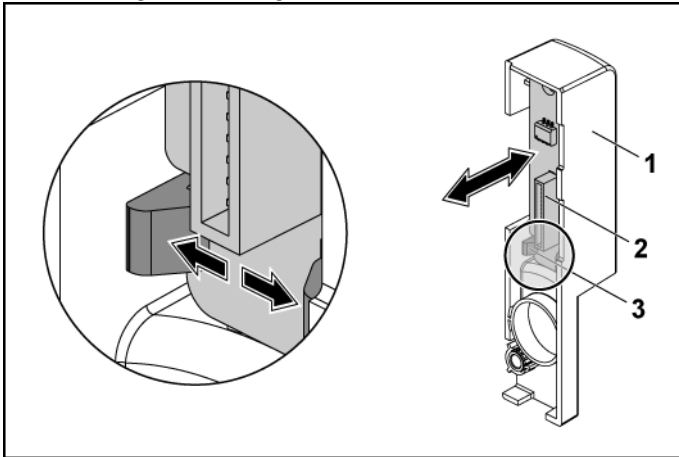

- 1 front-panel assembly
- 3 retention hooks

- 2 front panel

Installing the Front Panel



CAUTION: Many repairs may only be done by a certified service technician. You should only perform troubleshooting and simple repairs as authorized in your product documentation, or as directed by the online or telephone service and support team. Damage due to servicing that is not authorized by Dell is not covered by your warranty. Read and follow the safety instructions that came with the product.

- 1 Push aside the retention hooks on the front-panel assembly and place the front panel into the front-panel assembly. See Figure 3-55.
- 2 Replace the front-panel assembly into the hard-drive cage. See Figure 3-54.
- 3 Replace the screws that secure the front-panel assembly to the hard-drive cage. See Figure 3-54.

- 4 Replace the hard-drive cage into the chassis. See Figure 3-48.
- 5 Replace the screws that secure the front-panel assemblies to the chassis. See Figure 3-48.
- 6 Replace the screws that secure the hard-drive cage to the chassis. See Figure 3-47.
- 7 Connect front panel cables to the fan controller board. See Figure 3-41. You must route these cables properly through the tabs on the chassis to prevent them from being pinched or crimped.
- 8 Connect all the cables to the backplane. See Figure 5-3 for 3.5-inch hard drives and Figure 5-6 for 2.5-inch hard drives. You must route these cables properly through the tabs on the chassis to prevent them from being pinched or crimped.
- 9 Close the system. See "Closing the System" on page 143.
- 10 Replace the hard drives. See "Installing a Hard Drive into a Hard-Drive Carrier" on page 88.
- 11 Reconnect the system to its electrical outlet and turn on the system, including any attached peripherals.

Sensor Boards

Removing the Sensor Board for 3.5" HDD System



CAUTION: Many repairs may only be done by a certified service technician. You should only perform troubleshooting and simple repairs as authorized in your product documentation, or as directed by the online or telephone service and support team. Damage due to servicing that is not authorized by Dell is not covered by your warranty. Read and follow the safety instructions that came with the product.

- 1 Turn off the system, including any attached peripherals, and disconnect the system from the electrical outlet.
- 2 Remove all the hard drives. See "Removing a Hard-Drive Carrier" on page 85.



CAUTION: To prevent damage to the drives and backplane, you must remove the hard drives from the system before removing the backplane.



CAUTION: You must note the number of each hard drive and temporarily label them before removal so that you can replace them in the same locations.

- 3 Open the system. See "Opening the System" on page 142.
- 4 Disconnect all the cables from the backplane. See Figure 5-3 for 3.5-inch hard drives.

Note the routing of the cable underneath the tabs on the chassis as you remove them from the system. You must route these cables properly when you replace them to prevent the cables from being pinched or crimped.

- 5 Disconnect front panel cables from the fan controller board. See Figure 5-12.

Note the routing of the cable underneath the tabs on the chassis as you remove them from the system. You must route these cables properly when you replace them to prevent the cables from being pinched or crimped.

- 6 Remove the screws that secure the hard-drive cage to the chassis. See Figure 3-47.
- 7 Remove the hard drive cage from the chassis. See Figure 3-48.
- 8 Disconnect the cable from the sensor board. See Figure 5-14.
- 9 Remove the screw that secure the sensor board to the hard drive cage. See Figure 3-56.
- 10 Remove the sensor board from the hard drive cage. See Figure 3-56.

Figure 3-56. Removing and Installing the Sensor Board

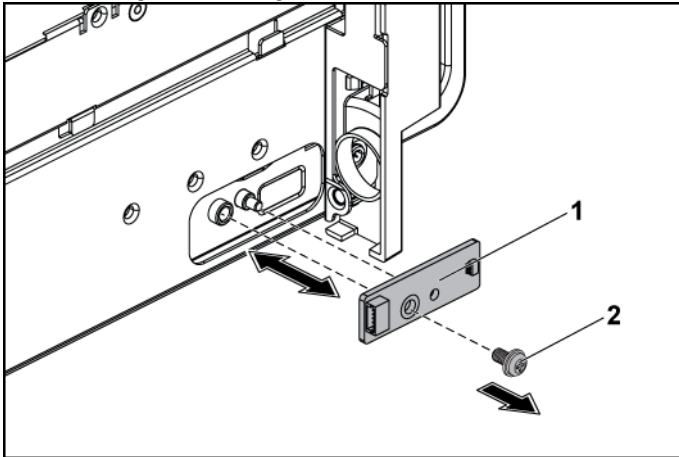

1 sensor board

2 screw

Installing the Sensor Board for 3.5" HDD System



CAUTION: Many repairs may only be done by a certified service technician. You should only perform troubleshooting and simple repairs as authorized in your product documentation, or as directed by the online or telephone service and support team. Damage due to servicing that is not authorized by Dell is not covered by your warranty. Read and follow the safety instructions that came with the product.

- 1 Replace the sensor board into the hard drive cage. See Figure 3-56.
- 2 Replace the screw that secure the sensor board to the hard drive cage. See Figure 3-32.
- 3 Connect the sensor board cable to the sensor board. See Figure 5-14.
- 4 Replace the hard drive cage into the chassis. See Figure 3-48.
- 5 Replace the screws that secure the hard-drive cage to the chassis. See Figure 3-47.

- 6 Connect all the cables to the backplane. See Figure 5-3 for 3.5-inch hard drives.
You must route these cables properly through the tabs on the chassis to prevent them from being pinched or crimped.
- 7 Connect front panel cables to the fan controller board. See Figure 5-12.
You must route these cables properly through the tabs on the chassis to prevent them from being pinched or crimped.
- 8 Close the system. See "Closing the System" on page 143.
- 9 Replace the hard drives. See "Installing a Hard Drive into a Hard-Drive Carrier" on page 88.
- 10 Reconnect the system to its electrical outlet and turn on the system, including any attached peripherals.

Removing the Sensor Board for 2.5" HDD System



CAUTION: Many repairs may only be done by a certified service technician. You should only perform troubleshooting and simple repairs as authorized in your product documentation, or as directed by the online or telephone service and support team. Damage due to servicing that is not authorized by Dell is not covered by your warranty. Read and follow the safety instructions that came with the product.

- 1 Turn off the system, including any attached peripherals, and disconnect the system from the electrical outlet.
- 2 Remove all the hard drives. See "Removing a Hard-Drive Carrier" on page 85.



CAUTION: To prevent damage to the drives and backplane, you must remove the hard drives from the system before removing the backplane.



CAUTION: You must note the number of each hard drive and temporarily label them before removal so that you can replace them in the same locations.

- 3 Open the system. See "Opening the System" on page 142.

- 4 Disconnect all the cables from the backplane. See Figure 5-6 for 2.5-inch hard drives.

Note the routing of the cable underneath the tabs on the chassis as you remove them from the system. You must route these cables properly when you replace them to prevent the cables from being pinched or crimped.

- 5 Disconnect front panel cables from the fan controller board. See Figure 5-12.

Note the routing of the cable underneath the tabs on the chassis as you remove them from the system. You must route these cables properly when you replace them to prevent the cables from being pinched or crimped.

- 6 Remove the hard drive cage from the chassis. See Figure 3-48

- 7 Disconnect the cable from the sensor board assembly. See Figure 5-14.

- 8 Remove the screw that secure the sensor board assembly to the hard drive cage. See Figure 3-57.

- 9 Remove the sensor board assembly from the hard drive cage. See Figure 3-57.

Figure 3-57. Removing and Installing the Sensor Board Assembly

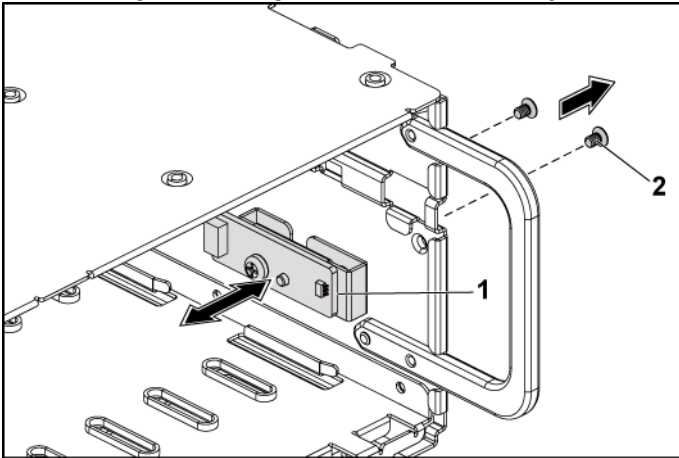

1 sensor board assembly

2 screw (2)

10 Remove the screw that secures the sensor board to the sensor-board holder. See Figure 3-58.

11 Remove the sensor board from the sensor-board holder. See Figure 3-58.

Figure 3-58. Removing and Installing the Sensor Board

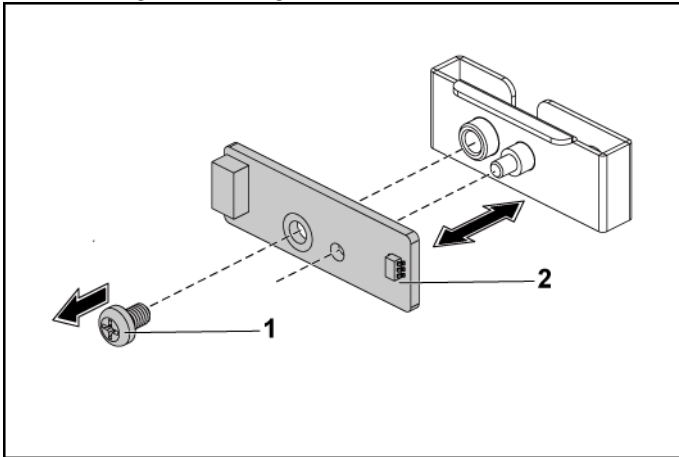

1 screw

2 sensor-board holder

Installing the Sensor Board for 2.5" HDD System



CAUTION: Many repairs may only be done by a certified service technician. You should only perform troubleshooting and simple repairs as authorized in your product documentation, or as directed by the online or telephone service and support team. Damage due to servicing that is not authorized by Dell is not covered by your warranty. Read and follow the safety instructions that came with the product.

- 1 Replace the sensor board into the sensor-board holder. See Figure 3-58.
- 2 Replace the sensor board assembly into the hard drive cage. See Figure 3-57.
- 3 Replace the screw that secure the sensor board to the hard drive cage. See Figure 3-57.
- 4 Connect the sensor board cable to the sensor board. See Figure 5-14.
- 5 Replace the hard drive cage into the chassis. See Figure 3-48.
- 6 Replace the screws that secure the hard-drive cage to the chassis. See Figure 3-47.

- 7 Connect all the cables to the backplane. See Figure 5-6 for 2.5-inch hard drives.
You must route these cables properly through the tabs on the chassis to prevent them from being pinched or crimped.
- 8 Connect front panel cables to the fan controller board. See Figure 5-12.
You must route these cables properly through the tabs on the chassis to prevent them from being pinched or crimped.
- 9 Close the system. See "Closing the System" on page 143.
- 10 Replace the hard drives. See "Installing a Hard Drive into a Hard-Drive Carrier" on page 88.
- 11 Reconnect the system to its electrical outlet and turn on the system, including any attached peripherals.

Troubleshooting Your System

Safety First – For You and Your System



WARNING: Whenever you need to lift the system, get others to assist you. To avoid injury, do not attempt to lift the system by yourself.



WARNING: Before removing the system cover, disconnect all power, then unplug the AC power cord, and then disconnect all peripherals, and all LAN lines.



CAUTION: Many repairs may only be done by a certified service technician. You should only perform troubleshooting and simple repairs as authorized in your product documentation, or as directed by the online or telephone service and support team. Damage due to servicing that is not authorized by Dell is not covered by your warranty. Read and follow the safety instructions that came with the product.

Installation Problems

Perform the following checks when you troubleshoot installation problems:

- Check all cable and power connections (including all rack cable connections).
- Unplug the power cord and wait for 1 minute. Then reconnect the power cord and try again.
- If the network is reporting an error, verify that the system has enough memory and disk space.
- Remove all added peripherals, one at a time, and try to turn on the system. If after removing a peripheral the system works, it may be a problem with the peripheral or a configuration problem between the peripheral and the system. Contact the peripheral vendor for assistance.

- If the system does not power on, check the LED display. If the power LED is not on, you may not be receiving AC power. Check the AC power cord to make sure that it is securely connected.

Troubleshooting System Startup Failure

If your system halts during startup, especially after installing an operating system or reconfiguring your system's hardware, check for invalid memory configurations. These could cause the system to halt at startup without any video output. See "System Memory" on page 131.

For all other startup issues, note any system messages that appear onscreen. See "Using the System Setup Program" on page 37 for more information.

Troubleshooting External Connections

Ensure that all external cables are securely attached to the external connectors on your system before troubleshooting any external devices. See Figure 1-1, Figure 1-3, and Figure 1-6 for the front- and back-panel connectors on your system.

Troubleshooting the Video Subsystem

- 1 Check the system and power connections to the monitor.
- 2 Check the video interface cabling from the system to the monitor.

Troubleshooting a USB Device

Use the following steps to troubleshoot a USB keyboard and/or mouse. For other USB devices, go to step 5.

- 1 Disconnect the keyboard and mouse cables from the system briefly and reconnect them.

- 2 If the problem is resolved, restart the system, enter the System Setup program, and check if the nonfunctioning USB ports are enabled.
- 3 Replace the keyboard/mouse with another working keyboard/mouse. If the problem is resolved, replace the faulty keyboard/mouse. If the problem is not resolved, proceed to the next step to begin troubleshooting the other USB devices attached to the system.
- 4 Power down all attached USB devices and disconnect them from the system.
- 5 Restart the system and, if your keyboard is functioning, enter the system setup program. Verify that all USB ports are enabled. See "USB Configuration" on page 54.
- 5 If your keyboard is not functioning, you can also use remote access. If the system is not accessible, see "

Jumper Settings" on page 212 for instructions on setting the NVRAM_CLR jumper inside your system and restoring the BIOS to the default settings.

- 6 Reconnect and power on each USB device one at a time.
- 7 If a device causes the same problem, power down the device, replace the USB cable, and power up the device.
If the problem persists, replace the device.
If all troubleshooting fails, see "Getting Help" on page 215.

Troubleshooting a Serial I/O Device

- 1 Turn off the system and any peripheral devices connected to the serial port.
- 2 Swap the serial interface cable with another working cable, and turn on the system and the serial device.
If the problem is resolved, replace the interface cable.
- 3 Turn off the system and the serial device, and swap the device with a comparable device.
- 4 Turn on the system and the serial device.
If the problem is resolved, replace the serial device.
If the problem persists, see "Getting Help" on page 215.

Troubleshooting a NIC

- 1 Restart the system and check for any system messages pertaining to the NIC controller.
- 2 Check the appropriate indicator on the NIC connector. See "NIC Indicators (BMC Management Port)" on page 21.
 - If the link indicator does not light, check all cable connections.
 - If the activity indicator does not light, the network driver files might be damaged or missing.

Remove and reinstall the drivers if applicable. See the NIC's documentation.

- Change the auto-negotiation setting, if possible.
- Use another connector on the switch or hub.

If you are using a NIC card instead of an integrated NIC, see the documentation for the NIC card.

- 3 Ensure that the appropriate drivers are installed and the protocols are bound. See the documentation for the NIC card.
- 4 Enter the System Setup program and confirm that the NIC ports are enabled. See "Using the System Setup Program" on page 37.
- 5 Ensure that the NICs, hubs, and switches on the network are all set to the same data transmission speed. See the documentation for each network device.
- 6 Ensure that all network cables are of the proper type and do not exceed the maximum length.

If all troubleshooting fails, see "Getting Help" on page 215.

Troubleshooting a Wet System



CAUTION: Many repairs may only be done by a certified service technician. You should only perform troubleshooting and simple repairs as authorized in your product documentation, or as directed by the online or telephone service and support team. Damage due to servicing that is not authorized by Dell is not covered by your warranty. Read and follow the safety instructions that came with the product.

- 1 Turn off the system and attached peripherals, and disconnect the system from the electrical outlet.
- 2 Open the system. See "Opening the System" on page 142.
- 3 Disassemble components from the system. See "Installing System Components" on page 82.
 - Hard drives
 - SAS backplane

- Expansion-card
 - Power supplies
 - Fans
 - Processors and heat sinks
 - Memory modules
- 4 Let the system dry thoroughly for at least 24 hours.
 - 5 Reinstall the components you removed in step 3.
 - 6 Close the system. See "Closing the System" on page 143.
 - 7 Reconnect the system to the electrical outlet, and turn on the system and attached peripherals.
If the system does not start properly, see "Getting Help" on page 215.
 - 8 If the system starts properly, shut down the system and reinstall the expansion card that you removed. See "Installing the Expansion Card" on page 101.
 - 9 If the system fails to start, see "Getting Help" on page 215.

Troubleshooting a Damaged System



CAUTION: Many repairs may only be done by a certified service technician. You should only perform troubleshooting and simple repairs as authorized in your product documentation, or as directed by the online or telephone service and support team. Damage due to servicing that is not authorized by Dell is not covered by your warranty. Read and follow the safety instructions that came with the product.

- 1 Turn off the system and attached peripherals, and disconnect the system from the electrical outlet.
- 2 Open the system. See "Opening the System" on page 142.
- 3 Ensure that the following components are properly installed:
 - Expansion-card assembly
 - Power supplies
 - Fans
 - Processors and heat sinks

- Memory modules
 - Hard-drive carriers
- 4 Ensure that all cables are properly connected.
 - 5 Close the system. See "Closing the System" on page 143.
 - 6 If the system fails to start, see "Getting Help" on page 215.

Troubleshooting the System Battery



NOTE: If the system is turned off for long periods of time (for weeks or months), the NVRAM may lose its system configuration information. This situation is caused by a defective battery.

- 1 Re-enter the time and date through the System Setup program. See "System Setup Options at Boot" on page 38.
- 2 Turn off the system and disconnect it from the electrical outlet for at least one hour.
- 3 Reconnect the system to the electrical outlet and turn on the system.
- 4 Enter the System Setup program.

If the date and time are not correct in the System Setup program, replace the battery. See "Replacing the System Battery" on page 138.



CAUTION: Many repairs may only be done by a certified service technician. You should only perform troubleshooting and simple repairs as authorized in your product documentation, or as directed by the online or telephone service and support team. Damage due to servicing that is not authorized by Dell is not covered by your warranty. Read and follow the safety instructions that came with the product.

If the problem is not resolved by replacing the battery, see "Getting Help" on page 215.



NOTE: Some software may cause the system time to speed up or slow down. If the system seems to operate normally except for the time kept in the System Setup program, the problem may be caused by software rather than by a defective battery.

Troubleshooting Power Supplies

- 1 Identify the faulty power supply by the power supply's fault indicator.
See "

2 NIC Status Indicator (Link/Activity)	Condition
Solid green	LAN linking/Accessing
Off	No link

- 3 Power and System Board Indicator Codes" on page 21.



CAUTION: At least one power supply must be installed for the system to operate. Operating the system with only one power supply installed for extended periods of time can cause the system to overheat.

- 4 Reseat the power supply by removing and reinstalling it. See "Power Supplies" on page 89.



NOTE: After installing a power supply, allow several seconds for the system to recognize the power supply and to determine if it is working properly. The power indicator turns green to signify that the power supply is functioning properly.

If the problem persists, replace the faulty power supply.

- 5 If all troubleshooting fails, see "Getting Help" on page 215.

Troubleshooting System Cooling Problems



CAUTION: Many repairs may only be done by a certified service technician. You should only perform troubleshooting and simple repairs as authorized in your product documentation, or as directed by the online or telephone service and support team. Damage due to servicing that is not authorized by Dell is not covered by your warranty. Read and follow the safety instructions that came with the product.

Ensure that none of the following conditions exist:

- System cover, cooling shroud, drive blank, power supply blank, or front or back filler panel is removed.
- Ambient temperature is too high.

- External airflow is obstructed.
- Cables inside the system obstruct airflow.
- An individual cooling fan is removed or has failed. See "Troubleshooting a Fan" on page 189.

Troubleshooting a Fan



CAUTION: Many repairs may only be done by a certified service technician. You should only perform troubleshooting and simple repairs as authorized in your product documentation, or as directed by the online or telephone service and support team. Damage due to servicing that is not authorized by Dell is not covered by your warranty. Read and follow the safety instructions that came with the product.

- 1 Locate the faulty fan indicated by the diagnostic software.
- 2 Turn off the system and all attached peripherals.
- 3 Open the system. See "Opening the System" on page 142.
- 4 Reseat the fan's power cable.
- 5 Restart the system.

If the fan functions properly, close the system. See "Closing the System" on page 143.

- 6 If the fan does not function, turn off the system and install a new fan. See "Cooling Fans" on page 144.
- 7 Restart the system.
If the problem is resolved, close the system. See "Closing the System" on page 143.
If the replacement fan does not operate, see "Getting Help" on page 215.

Troubleshooting System Memory



CAUTION: Many repairs may only be done by a certified service technician. You should only perform troubleshooting and simple repairs as authorized in your product documentation, or as directed by the online or telephone service and support team. Damage due to servicing that is not authorized by Dell is not covered by your warranty. Read and follow the safety instructions that came with the product.



NOTE: Invalid memory configurations can cause your system to halt at startup without video output. See "System Memory" on page 131 and verify that your memory configuration complies with all applicable guidelines.

- 1 If the system is not operational, turn off the system and attached peripherals, and unplug the system from the power source. Wait at least 10 seconds and then reconnect the system to power.
- 2 Turn on the system and attached peripherals and note the messages on the screen.
Go to step 10 if an error message appears indicating a fault with a specific memory module.

- 3 Enter the System Setup program and check the system memory settings.
See "System Memory" on page 43. Make any changes to the memory settings, if needed.
If the memory settings match the installed memory but a problem is still indicated, go to step 10.
- 4 Turn off the system and attached peripherals, and disconnect the system from the electrical outlet.
- 5 Remove the system-board assembly. See "Removing a System-Board Assembly" on page 92.
- 6 Reseat the memory modules in their sockets. See "Installing the Memory Modules" on page 134.
- 7 Install the system-board assembly. See "Installing a System-Board Assembly" on page 93.
- 8 Reconnect the system to its electrical outlet, and turn on the system and attached peripherals.
- 9 Enter the System Setup program and check the system memory settings. See "System Memory" on page 43.
If the problem is not resolved, proceed with the next step.
- 10 Turn off the system and attached peripherals, and disconnect the system from the power source.
- 11 Remove the system-board assembly. See "Removing a System-Board Assembly" on page 92.
- 12 If a diagnostic test or error message indicates a specific memory module as faulty, swap or replace the module.
- 13 To troubleshoot an unspecified faulty memory module, replace the memory module in the first DIMM socket with a module of the same type and capacity. See "Installing the Memory Modules" on page 134.
- 14 Install the system-board assembly. See "Removing a System-Board Assembly" on page 92.

- 15 Reconnect the system to its electrical outlet, and turn on the system and attached peripherals.
- 16 As the system boots, observe any error message that appears and the diagnostic indicators on the front of the system.
- 17 If the memory problem is still indicated, repeat step 10 through step 16 for each memory module installed.
If the problem persists after all memory modules have been checked, see "Getting Help" on page 215.

Troubleshooting a Hard Drive



CAUTION: Many repairs may only be done by a certified service technician. You should only perform troubleshooting and simple repairs as authorized in your product documentation, or as directed by the online or telephone service and support team. Damage due to servicing that is not authorized by Dell is not covered by your warranty. Read and follow the safety instructions that came with the product.



CAUTION: This troubleshooting procedure can destroy data stored on the hard drive. Before you proceed, back up all files on the hard drive.

- 1 If your system has a RAID controller and your hard drives are configured in a RAID array, perform the following steps:
 - a. Restart the system and enter the host adapter configuration utility program by pressing <Ctrl> <H> for LSI 9260 / 9265 or <Ctrl> <C> for a SAS 2008 daughter card.
See the documentation supplied with the host adapter for information about the configuration utility.
 - b. Ensure that the hard drive(s) have been configured correctly for the RAID array.
 - c. Take the hard drive offline and reseal the drive. See "Removing a Hard Drive From a Hard-Drive Carrier" on page 87.

- d. Exit the configuration utility and allow the system to boot to the operating system.
- 2 Ensure that the required device drivers for your controller card are installed and are configured correctly. See the operating system documentation for more information.
- 3 Restart the system, enter the System Setup program, and verify that the controller is enabled and the drives appear in the System Setup program.
See "Using the System Setup Program" on page 37.
If the problem persists, see "Getting Help" on page 215.

Troubleshooting a Storage Controller



NOTE: When troubleshooting a SAS RAID controller, also see the documentation for your operating system and the controller.

- 1 Enter the System Setup program and ensure that the SAS controller is enabled. See "Using the System Setup Program" on page 37.
- 2 Restart the system and press the applicable key sequence to enter the configuration utility program.
 - <Ctrl><C> for a SAS 2008 daughter card
 - <Ctrl><H> for a LSI 9260-8i card or a LSI 9265-8i cardSee the controller's documentation for information about configuration settings.
- 3 Check the configuration settings, make any necessary corrections, and restart the system.



CAUTION: Many repairs may only be done by a certified service technician. You should only perform troubleshooting and simple repairs as authorized in your product documentation, or as directed by the online or telephone service and support team. Damage due to servicing that is not authorized by Dell is not covered by your warranty. Read and follow the safety instructions that came with the product.

- 4 Turn off the system and attached peripherals, and disconnect the system from its electrical outlet.
- 5 Remove the system-board assembly. See "Removing a System-Board Assembly" on page 92.
- 6 Ensure that the controller card is firmly seated into the system board connector. See "Installing the Expansion Card" on page 101.
- 7 If you have a battery-cached SAS RAID controller, ensure that the RAID battery is properly connected and, if applicable, the memory module on the RAID card is properly seated.
- 8 Ensure that the cables are firmly connected to the storage controller and the SAS backplane board.
- 9 Install the system-board assembly. See "Installing a System-Board Assembly" on page 93.
- 10 Reconnect the system to its electrical outlet, and turn on the system and attached peripherals.
If the problem persists, see "Getting Help" on page 215.

Troubleshooting Expansion Cards



NOTE: When troubleshooting an expansion card, see the documentation for your operating system and the expansion card.



CAUTION: Many repairs may only be done by a certified service technician. You should only perform troubleshooting and simple repairs as authorized in your product documentation, or as directed by the online or telephone service and support team. Damage due to servicing that is not authorized by Dell is not covered by your warranty. Read and follow the safety instructions that came with the product.

- 1 Turn off the system and attached peripherals, and disconnect the system from the electrical outlet.
- 2 Remove the system-board assembly. See "Removing a System-Board Assembly" on page 92.
- 3 Ensure that each expansion card is firmly seated in its connector. See "Installing the Expansion Card" on page 101.
- 4 Install the system-board assembly. See "Installing a System-Board Assembly" on page 93.
- 5 Reconnect the system to the electrical outlet, and turn on the system and attached peripherals.
- 6 If the problem is not resolved, see "Getting Help" on page 215.

Troubleshooting Processors



CAUTION: Many repairs may only be done by a certified service technician. You should only perform troubleshooting and simple repairs as authorized in your product documentation, or as directed by the online or telephone service and support team. Damage due to servicing that is not authorized by Dell is not covered by your warranty. Read and follow the safety instructions that came with the product.

- 1 Turn off the system and attached peripherals, and disconnect the system from the electrical outlet.
- 2 Remove the system-board assembly. See "Removing a System-Board Assembly" on page 92.
- 3 Ensure that each processor and heat sink are properly installed. See "Installing a Processor" on page 97.
- 4 Install the system-board assembly. See "Installing a System-Board Assembly" on page 93.
- 5 Reconnect the system to the electrical outlet, and turn on the system and attached peripherals.
- 6 If the problem persists, turn off the system and attached peripherals, and disconnect the system from the electrical outlet.
- 7 Remove the system-board assembly. See "Removing a System-Board Assembly" on page 92.
- 8 Remove processor 2. See "Removing a Processor" on page 96.
- 9 Install the system-board assembly. See "Installing a System-Board Assembly" on page 93.
- 10 Reconnect the system to the electrical outlet, and turn on the system and attached peripherals.
If the problem persists, the processor is faulty. See "Getting Help" on page 215.
- 11 Turn off the system and attached peripherals, and disconnect the system from the electrical outlet.

- 12 Remove the system-board assembly. See "Removing a System-Board Assembly" on page 92.
- 13 Replace processor 1 with processor 2. See "Installing a Processor" on page 97.
- 14 Repeat step 9 through step 11.
If you have tested both the processors and the problem persists, the system board is faulty. See "Getting Help" on page 215.

IRQ Assignment Conflicts

Most PCI devices can share an IRQ with another device, but they cannot use an IRQ simultaneously. To avoid this type of conflict, see the documentation for each PCI device for specific IRQ requirements.

Table 4-1. Assignment Specific IRQ Requirements

IRQ Line	Assignment	IRQ Line	Assignment
IRQ0	8254 timer	IRQ8	RTC
IRQ1	Keyboard controller	IRQ9	SCI
IRQ2	Cascade for IRQ9	IRQ10	USB controller, NIC
IRQ3	Serial port	IRQ11	VGA, USB controller
IRQ4	Serial port	IRQ12	Mouse controller
IRQ5	Free	IRQ13	Processor
IRQ6	Free	IRQ14	Primary IDE controller
IRQ7	USB controller	IRQ15	Secondary IDE controller

Jumpers and Connectors

System Board Connectors

This section provides specific information about the system jumpers. It also provides some basic information on jumpers and switches and describes the connectors on the various boards in the system.

Figure 5-1. System Board Connectors

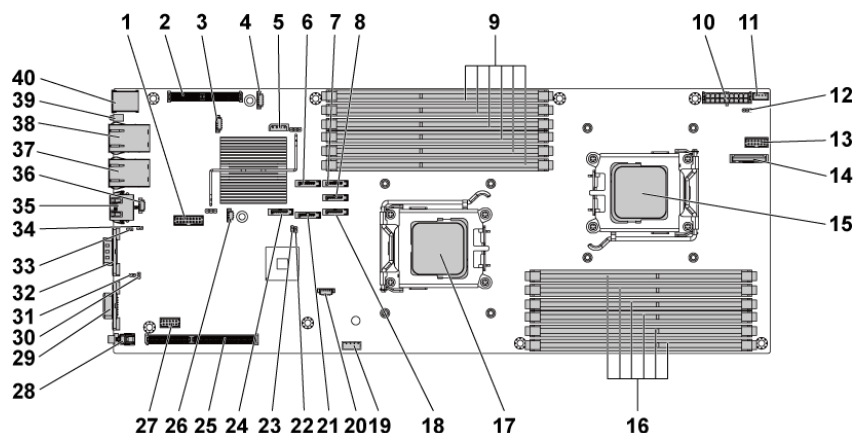

- | | | | |
|----|-----------------------------------|----|-------------------------------|
| 1 | LAN LED connector | 2 | PCI-E daughter card connector |
| 3 | SGPIO connector 2 | 4 | SGPIO connector 1 |
| 5 | IPMB connector | 6 | onboard SATA2 connector 5 |
| 7 | onboard SATA2 connector 3 | 8 | onboard SATA2 connector 2 |
| 9 | DIMM sockets for processor 1 | 10 | main power connector |
| 11 | *BMC ID / ACK connector (reserve) | 12 | *VR code update connector |
| 13 | front panel connector | 14 | system battery |

15	processor 0	16	DIMM sockets for processor 0
17	processor 1	18	onboard SATA2 connector 1
19	internal USB connector	20	*SSD power
21	onboard SATA2 connector 4	22	password jumper
23	BIOS recovery jumper	24	onboard SATA2 connector 6
25	expansion slot	26	*MEZZ type
27	internal COM connector	28	power button
29	VGA port	30	BMC disable jumper
31	*VDDR 1.2V/1.05V switch	32	serial port
33	clear CMOS jumper	34	COM switch
35	management port	36	*LOM connector
37	NIC2 connector (RJ45)	38	NIC1 connector (RJ45)
39	ID LED	40	USB ports



NOTE: * means these connectors are only for PYRRT and 0G5FD.

Backplane Connectors

3.5" Hard-Drive Backplane

Figure 5-2. Front View of the Backplane

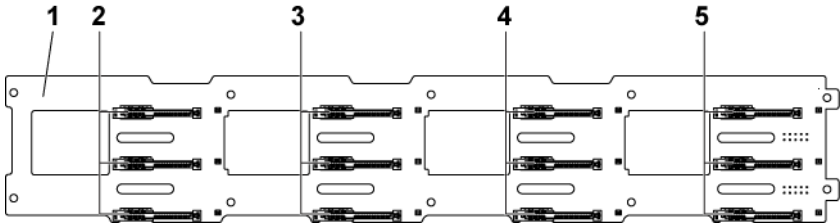

- 1 3.5" backplane
- 2 SATA2 and SAS connectors 1, 2 and 3 for system board 1 (from top to bottom)
- 3 SATA2 and SAS connector 1, 2 and 3 for system board 2 (from top to bottom)
- 4 SATA2 and SAS connectors 1, 2 and 3 for system board 3 (from top to bottom)
- 5 SATA2 and SAS connectors 1, 2 and 3 for system board 4 (from top to bottom)

Figure 5-3. Back View of the Backplane

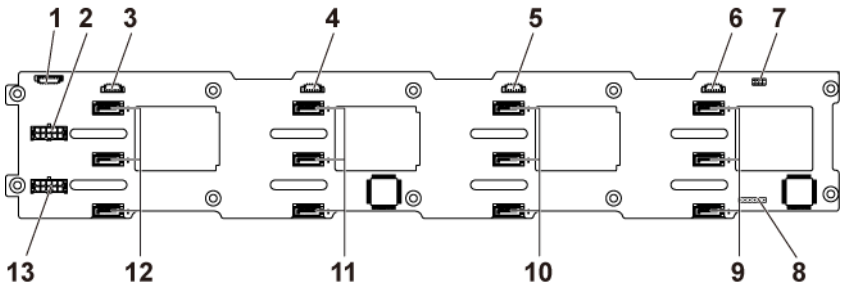

- | | | | |
|----|---|----|---|
| 1 | fan controller board connector | 2 | backplane power connector for power supply 1 |
| 3 | SGPIO connector for system board 4 | 4 | SGPIO connector for system board 3 |
| 5 | SGPIO connector for system board 2 | 6 | SGPIO connector for system board 1 |
| 7 | backplane jumper | 8 | CPLD JTAG connector |
| 9 | SATA2 hard drive connectors 1, 2, and 3 for system board 1 (from top to bottom) | 10 | SATA2 hard drive connectors 1, 2, and 3 for system board 2 (from top to bottom) |
| 11 | SATA2 hard drive connectors 1, 2, and 3 for system board 3 (from top to bottom) | 12 | SATA2 hard drive connectors 1, 2, and 3 for system board 4 (from top to bottom) |
| 13 | backplane power connector for power supply 2 | | |

2.5" Hard-Drive Backplane

Figure 5-4. Front View of the Backplane

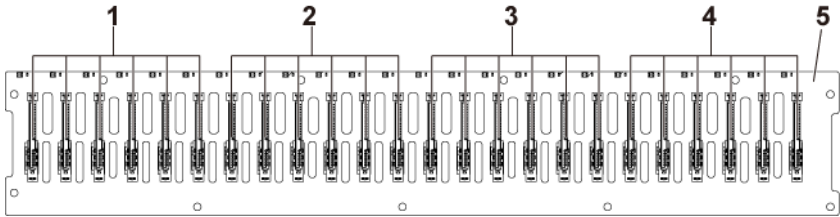

- | | | | |
|---|---|---|---|
| 1 | SATA2 and SAS connectors 1 to 6 for system board 1 (from left to right) | 2 | SATA2 and SAS connectors 1 to 6 for system board 2 (from left to right) |
| 3 | SATA2 and SAS connectors 1 to 6 for system board 3 (from left to right) | 4 | SATA2 and SAS connectors 1 to 6 for system board 4 (from left to right) |
| 5 | 2.5" backplane | | |

Figure 5-5. Back View of the Backplane-Type 1

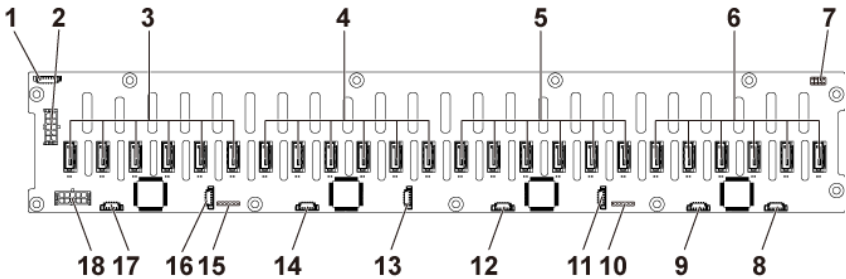

- | | | | |
|---|--|---|--|
| 1 | system-fan board connector | 2 | backplane power connector for power supply 1 |
| 3 | SATA2 hard drive connectors 1 to 6 for system board 4 (from right to left) | 4 | SATA2 hard drive connectors 1 to 6 for system board 3 (from right to left) |

- | | | | |
|----|--|----|--|
| 5 | SATA2 hard drive connectors 1 to 6 for system board 2 (from right to left) | 6 | SATA2 hard drive connectors 1 to 6 for system board 1 (from right to left) |
| 7 | backplane jumper | 8 | SGPIO connector A for system board 1 |
| 9 | SGPIO connector B for system board 1 | 10 | CPLD JTAG connector |
| 11 | SGPIO connector A for system board 2 | 12 | SGPIO connector B for system board 2 |
| 13 | SGPIO connector A for system board 3 | 14 | SGPIO connector B for system board 3 |
| 15 | CPLD JTAG connector | 16 | SGPIO connector A for system board 4 |
| 17 | SGPIO Connector B for system board 4 | 18 | backplane power connector for power supply 2 |

Figure 5-6. Back View of the Backplane-Type 2

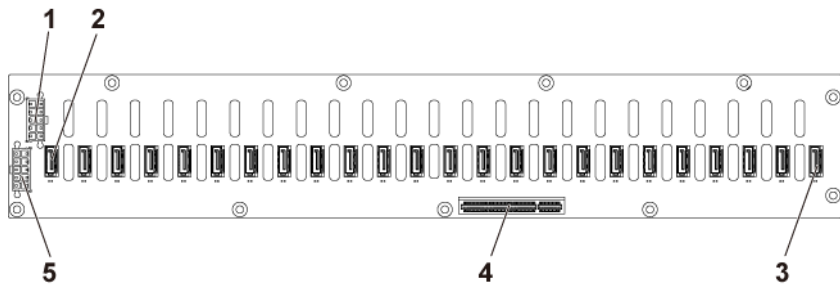

- | | | | |
|---|-------------------------------|---|---------------------------------|
| 1 | power supply connector 2 | 2 | HDD connector number 24-port 24 |
| 3 | HDD connector number 1-port 1 | 4 | PCIex8 connector |
| 5 | power supply connector 1 | | |

2.5" Hard-Drive Backplane Expander Card Connectors

Figure 5-7. Expander Card Connectors

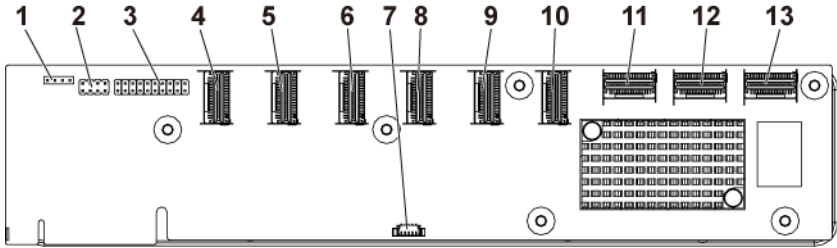

- | | | | |
|----|-----------------------------------|----|-----------------------------------|
| 1 | UART connector | 2 | expander card jumper |
| 3 | JTAG connector | 4 | mini-SAS connector 1 (port 1-4) |
| 5 | mini-SAS connector 2 (port 5-8) | 6 | mini-SAS connector 3 (port 9-12) |
| 7 | SGPIO connector | 8 | mini-SAS connector 4 (port 13-16) |
| 9 | mini-SAS connector 5 (port 17-20) | 10 | mini-SAS connector 6 (port 21-24) |
| 11 | system board 1 mini-SAS connector | 12 | system board 2 mini-SAS connector |
| 13 | system board 4 mini-SAS connector | | |

Middle Plane Connectors

Figure 5-8. Middle Plane Connectors

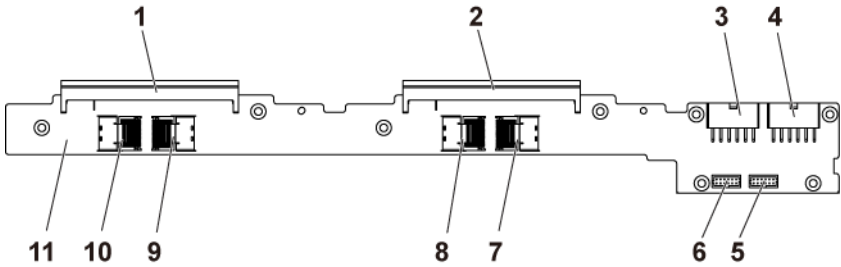

- | | | | |
|----|---|----|---|
| 1 | middle plane connector 1 | 2 | middle plane connector 2 |
| 3 | middle plane power connector for system board 1 and 2 | 4 | middle plane power connector for system board 3 and 4 |
| 5 | front panel connector for system boards 3 and 4 | 6 | front panel connector for system board 1 and 2 |
| 7 | mini-SAS connector for system boards 3 and 4 (hard drive 1,2,3 and 4) | 8 | mini-SAS connector for system board 3 and 4 (hard drive 5 and 6) |
| 9 | mini-SAS connector for system boards 1 and 2 (hard drive 1,2,3 and 4) | 10 | mini-SAS connector for system boards 1 and 2 (hard drive 5 and 6) |
| 11 | middle plane | | |

Interposer Extender Connectors

Figure 5-9. Interposer Extender Connectors

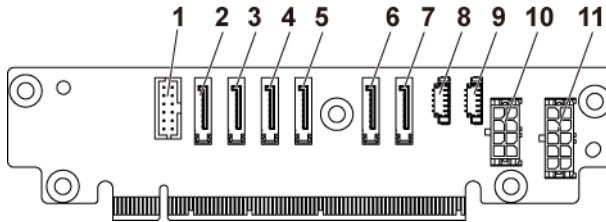

- | | | | |
|----|---------------------------|----|---------------------------|
| 1 | front panel connector | 2 | onboard SATA2 connector 1 |
| 3 | onboard SATA2 connector 2 | 4 | onboard SATA2 connector 3 |
| 5 | onboard SATA2 connector 4 | 6 | onboard SATA2 connector 5 |
| 7 | onboard SATA2 connector 6 | 8 | SGPIO connector A |
| 9 | SGPIO connector B | 10 | 2x4 pin power connector |
| 11 | 2x5 pin power connector | | |

SAS Daughter Card Connectors

Figure 5-10. SAS Daughter Card Connectors

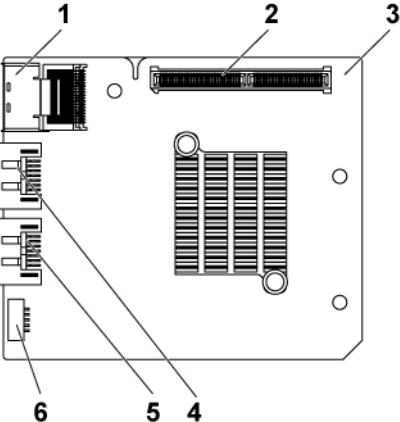

- | | | | |
|---|--------------------|---|-------------------------|
| 1 | mini-SAS connector | 2 | daughter card connector |
| 3 | daughter card | 4 | SAS port 4 |
| 5 | SAS port 5 | 6 | SGPIO connector B |

NIC Daughter Card Connectors

Figure 5-11. NIC Daughter Card Connectors

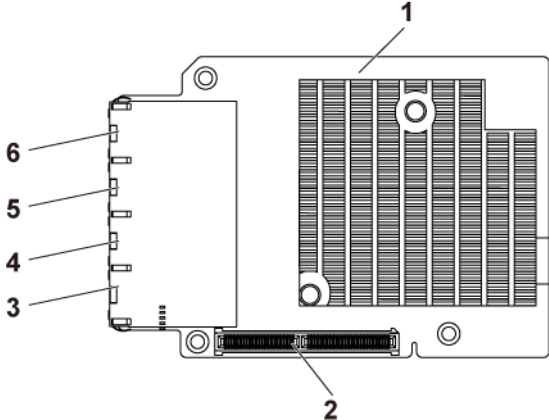

- | | | | |
|---|-----------------|---|-------------------------|
| 1 | daughter card | 2 | daughter card connector |
| 3 | NIC connector 4 | 4 | NIC connector 3 |
| 5 | NIC connector 2 | 6 | NIC connector 1 |

Fan Controller Board Connectors

Figure 5-12. Fan Controller Board Connectors

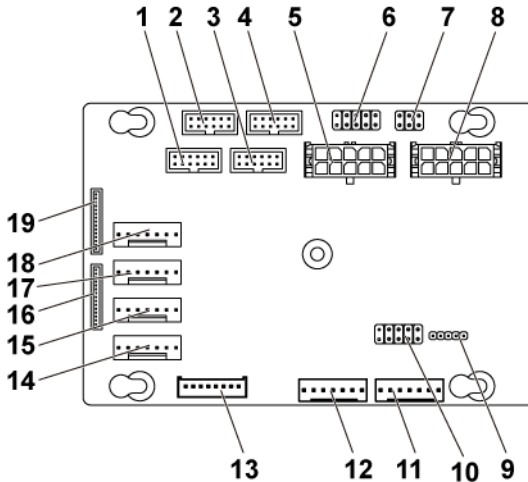

- | | | | |
|----|--|----|---|
| 1 | front panel connector for system board 4 | 2 | front panel connector for system board 2 |
| 3 | front panel connector for system board 1 | 4 | front panel connector for system board 3 |
| 5 | system fan board power connector 1 | 6 | *PIC firmware recovery and PS-ON connector |
| 7 | system fan speed control jumper | 8 | system fan board power connector 2 |
| 9 | PIC firmware update connector | 10 | product ID select and power throttling disable jumper |
| 11 | system fan board connector 2 | 12 | system fan board connector 1 |
| 13 | hard drive backplane connector | 14 | system fan connector 4 |
| 15 | system fan connector 3 | 16 | front panel connector 2 |
| 17 | system fan connector 2 | 18 | system fan connector 1 |
| 19 | front panel connector 1 | | |



NOTE: Pin 9 and pin 10 of PIC firmware recovery and PS-ON connector are used for firmware recovery, and pin 1-8 are used for debug when pin 9 and pin 10 are shorted by jumper.

Power Distribution Board Connectors

Figure 5-13. Power Distribution Board Connectors

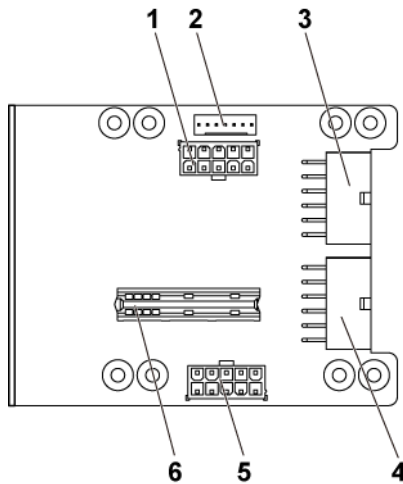

- | | | | |
|---|---|---|---|
| 1 | backplane power connector | 2 | system fan board connector |
| 3 | main power connector for system board 3 and 4 | 4 | main power connector for system board 1 and 2 |
| 5 | system fan board power connector | 6 | bridge card connector |

Sensor Board Connectors

Figure 5-14. Sensor Board Connectors

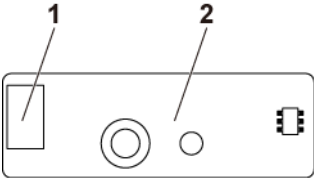

1 power connector

2 sensor board

Jumper Settings



CAUTION: Many repairs may only be done by a certified service technician. You should only perform troubleshooting and simple repairs as authorized in your product documentation, or as directed by the online or telephone service and support team. Damage due to servicing that is not authorized by Dell is not covered by your warranty. Read and follow the safety instructions that came with the product.

System Configuration Jumper Settings

The function of system configuration jumper installed on each system board is shown below:

Figure 5-15. System Configuration Jumpers

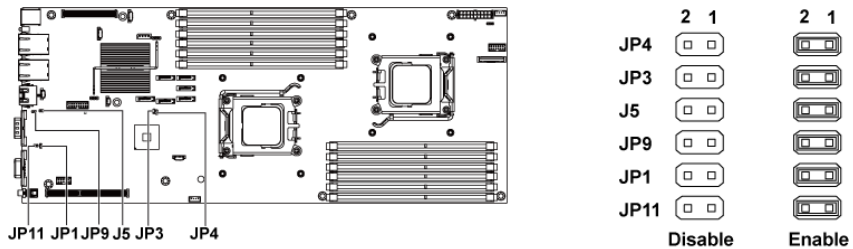

Table 5-1. System Configuration Jumper

Jumper	Function	Off	On
JP4	Clear Password	*Disable	Enable
JP3	BIOS Recovery	*Disable	Enable
J5	COM Port Switch**	*Disable	Enable
JP9	Clear CMOS	*Disable	Enable
JP1	BMC Configuration	*Disable	Enable
JP11	VDDR 1.2V/1.05V Switch***	*Disable	Enable



NOTE: The * in the table of system configuration jumper describes the default status and the default state is not active state.



NOTE: ** means if disabled, BMC Port 1 is set to internal and port 2 to external; if enabled, BMC Port 1 is set to external, and internal port has no function.



NOTE: *** means if disabled, 1.2V select for 95W and 65W CPU; if enabled, 1.05V select for 35W CPU.

Backplane Jumper Settings



CAUTION: Many repairs may only be done by a certified service technician. You should only perform troubleshooting and simple repairs as authorized in your product documentation, or as directed by the online or telephone service and support team. Damage due to servicing that is not authorized by Dell is not covered by your warranty. Read and follow the safety instructions that came with the product.

The function of jumpers installed on 3.5" backplane and 2.5" backplane is the same. Following is an example using the jumpers installed on 3.5" backplane.

Figure 5-16. Jumper Installed on Backplane



Table 5-2. Jumpers Installed on Backplane

Jumper	Function	Off	On
A	HDD Type Select	*Disable	Enable
B	SAS Code Select	*Disable	Enable
C	MFG Test	*Disable	Enable
D	LED Control	*Disable	Enable



NOTE: The * in the table of backplane jumper describes the default status and the default state is not active state. When connecting the 1CH SAS daughter card, insert the jumper cover onto the hard drive type select jumper. For onboard SATA2 connectors, do not insert the jumper cover onto the hard drive type select jumper.

Backplane Expander Card Jumper Settings



CAUTION: Many repairs may only be done by a certified service technician. You should only perform troubleshooting and simple repairs as authorized in your product documentation, or as directed by the online or telephone service and support team. Damage due to servicing that is not authorized by Dell is not covered by your warranty. Read and follow the safety instructions that came with the product.

The function of backplane jumper installed on the expander card is shown below:

Figure 5-17. Jumper Installed on Expander Card

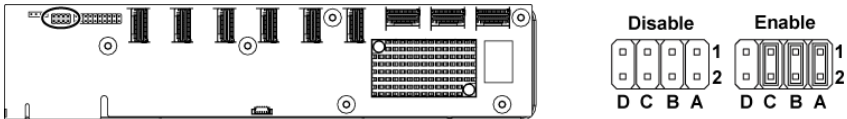

Table 5-3. Jumpers Installed on Expander Card

Jumper	Function	Off	On
A	SAS Card Selection	*Disable	Enable
B	MLB Mode Selection	*Disable	Enable
C	UART Selection	*Disable	Enable
D	Reserved	—	—



NOTE: The * in the table of system configuration jumper describes the default status and the default state is not active state.

Getting Help

Contacting Dell

For customers in the United States, call 800-WWW-DELL (800-999-3355).



NOTE: If you do not have an active Internet connection, you can find contact information on your purchase invoice, packing slip, bill, or Dell product catalog.

Dell provides several online and telephone-based support and service options. Availability varies by country and product, and some services may not be available in your area. To contact Dell for sales, technical support, or customer service issues:

- 1 Visit **support.dell.com**. Click your country/region at the bottom of the page. For a full listing of country/region, click **All**. Click **All Support** from **Support** menu.
- 2 Select the appropriate service or support link based on your need.
- 3 Choose the method of contacting Dell that is convenient for you.

Index

A

about your system, 11

B

back panel features, 18

backplane

installing, 164

removing, 161

backplane jumper settings, 213

batteries

troubleshooting, 187

battery (system)

replacing, 138

blank

hard drive, 84

C

cable routing

LSI 9260-8i card, 106, 150, 153

LSI 9265-8i card, 114

SAS daughter card, 123

collecting system event log, 24

contacting dell, 215

cooling fans

installing, 146

removing, 144

troubleshooting, 189

D

damaged systems

troubleshooting, 187

Dell

contacting, 215

drive blank

installing, 85

removing, 84

E

expansion card

installing, 101

removing, 99

troubleshooting, 195

expansion card connector

installing, 120

removing, 119

F

fan controller board installing,
152

fan controller board removing,
151

features and indicators

front panel, 12

front panel features, 12

front panel installing, 173

front panel removing, 170

H

hard drive

- installing hot-swap hard drive, 86
 - removing, 85
 - removing a hot-swap hard drive, 85
 - troubleshooting, 192
- ### heat sink installing, 95
- ### heat sink removing, 94
- ### heat sinks
- installing, 95
 - removing, 94

I

indicator codes

- AC power, 22
- hard-drive indicator, 14
- NIC, 20
- NIC (Management Port), 21
- power and system board, 21

indicators

- back panel, 18
- front panel, 12

installing

- backplanes, 164
- cooling fans, 146
- expander card, 169
- expansion card, 101
- expansion card connector, 120
- fan controller board, 152
- front panel, 173
- hard drive blank, 85
- heat sink, 95
- hot-swap hard drive, 86

interposer extender, 137

LSI 9260-8i card, 105

LSI 9260-8i RAID battery, 107, 108

LSI 9260-8i RAID battery carrier, 110

LSI 9265-8i card, 113

Mellanox card, 130

memory modules, 134

middle planes, 159

NIC daughter card, 126

power supply, 91

processor, 97

SAS daughter card, 122

sensor board, 176

system board, 141

system board assembly, 93

installing the LSI 9265-8i RAID Battery, 118

installing the LSI 9265-8i RAID Battery Assembly, 116

interposer extender

installing, 137

removing, 136

K

keyboards

troubleshooting, 183

L

LEDs

BMC heart beat, 23

LSI 9260-8i card

installing, 105

removing, 102

- LSI 9260-8i RAID battery
 - installing, 107, 108
- LSI 9260-8i RAID battery carrier
 - installing, 110
 - removing, 109
- LSI 9265-8i card
 - installing, 113
 - removing, 110
- LSI 9265-8i Card, 110
- LSI 9265-8i RAID Battery (Optional), 115

M

- Mellanox card
 - installing, 130
 - removing, 127
- memory
 - troubleshooting, 190
- memory modules
 - installing, 134
 - removing, 133
- memory modules (DIMMs)
 - configuring, 131
- middle planes
 - installing, 159
 - removing, 154

N

- NIC daughter card
 - installing, 126
 - removing, 124
- NIC Daughter Card, 124
- NICs

- troubleshooting, 185

P

- phone numbers, 215
- POST
 - accessing system features, 11
- power distribution board
 - removing, 147
- power supplies
 - installing, 91
 - removing, 90
- processor
 - installing, 97
 - removing, 96
- processors
 - troubleshooting, 196

R

- removing
 - backplanes, 161
 - cooling fans, 144
 - expander card, 165
 - expansion card, 99
 - expansion card connector, 119
 - fan controller board, 151
 - front panel, 170
 - hard drive, 85
 - hard drive blank, 84
 - heat sink, 94
 - hot-swap hard drive, 85
 - interposer extender, 136
 - LSI 9260-8i card, 102
 - LSI 9260-8i RAID battery

- carrier, 109
- LSI 9265-8i card, 110
- Mellanox card, 127
- memory modules (DIMMs), 133
- middle planes, 154
- NIC daughter card, 124
- power distribution board, 147
- power supply, 90
- processor, 96
- SAS daughter card, 121
- sensor board, 174
- system board, 140
- system board assembly, 92
- removing the LSI 9265-8i RAID Battery, 117
- removing the LSI 9265-8i RAID Battery, 115
- removing the Mellanox Card, 127
- replacing
 - system battery, 138

S

- safety, 82
- SAS controller daughter card
 - troubleshooting, 193
- SAS daughter card
 - installing, 122
 - removing, 121
- SAS RAID controller daughter card
 - troubleshooting, 193
- startup
 - accessing system features, 11
- support
 - contacting Dell, 215

- system
 - closing, 143
 - opening, 142
- system board
 - connectors, 198
 - installing, 141
 - jumper settings, 211
 - removing, 140
- system board assembly
 - installing, 93
 - removing, 92
- system cooling
 - troubleshooting, 189
- system features
 - accessing, 11
- system setup
 - boot settings configuration, 57
 - hyper-transport configuration, 52
 - LAN configuration, 61
 - memory configuration, 48
 - PCI configuration, 53
 - processor configuration, 44
 - processor settings, 42
 - remote access configuration, 62
 - SATA configuration, 50
 - system memory, 43
 - USB configuration, 54

T

- telephone number, 215
- troubleshooting
 - cooling fans, 189
 - damaged system, 187
 - expansion card, 195

- external connections, 183
- hard drive, 192
- keyboard, 183
- memory, 190
- NIC, 185
- processors, 196
- SAS RAID controller daughter card, 193
- sequence, 182
- system battery, 187
- system boot issues, 24
- system cooling, 189
- video, 183

- wet system, 186

V

- video
 - troubleshooting, 183

W

- warranty, 36
- wet system
 - troubleshooting, 186